

# H&S

## GM 170



### **WARNING**

READ AND UNDERSTAND THIS MANUAL  
BEFORE OPERATING THIS EQUIPMENT

**UNSAFE OPERATION OR MAINTENANCE OF THIS EQUIPMENT CAN RESULT IN  
SERIOUS INJURY OR DEATH**

## **OPERATOR'S MANUAL AND PARTS LIST**

Revision #1 10-08

HSMFG0106

Manufactured By  
**H&S MANUFACTURING CO., INC.**

P.O. BOX 768 (715) 387-3414 FAX (715) 384-5463  
MARSHFIELD, WISCONSIN 54449

**H&S GM 170**  
**OPERATOR'S & PARTS MANUAL**  
**CONTENTS**

Warranty & Warranty Registration Card. . . . .	1-2
Dealer Pre-Delivery & Delivery Checklist. . . . .	3-4
Be Alert Symbol. . . . .	5
Explanation of Safety Signs. . . . .	6
Danger - Warning Signs. . . . .	7-10
Warning - Owner Must Read and Understand. . . . .	13
Bolt Torque Chart. . . . .	14
Preparing for Operation. . . . .	15
Set-Up & Assembly. . . . .	16
Storage. . . . .	16
Transporting. . . . .	17
Operation. . . . .	18-26
Adjustments. . . . .	27-29
Lubrication Guide. . . . .	30-32
Service. . . . .	33-38
Optional Features & Accessories. . . . .	39-40
Troubleshooting Guide. . . . .	41-45
Decal Location & Identification. . . . .	46-49
Instructions for Ordering Parts - About Improvements. . . . .	50
Service and Parts Notes. . . . .	51
Parts. . . . .	52-86
Specifications. . . . .	Inside Back Cover

# WARRANTY

## H & S WARRANTY

H & S Manufacturing Co., Inc. ("H & S") warrants this product to be free from defect in material and workmanship. Except as noted below, this warranty term is twelve (12) months from the date of delivery of the product to the original purchaser by an authorized H & S dealer. Under this warranty, H & S will repair or replace, at its option, any covered part which is found to be defective in material or workmanship during the applicable warranty term. In no case will the covered repair cost of a part or parts exceed the replacement cost of that part. Warranty service must be performed by H & S or a dealer authorized by H & S to sell and/or service the product involved, which will use only new or remanufactured parts or components furnished by H & S. This warranty includes approved parts and labor to fix the product but does not include, and the purchaser is responsible for, any service call and/or transportation of the product to and from the dealer's place of business, for any premium charged for overtime labor requested by the purchaser, and for any service work not directly related to any defect covered under this warranty. This warranty includes only those components of the product manufactured by H & S. Warranty for any component not manufactured by H & S including, but not limited to, engines, batteries, tires, rims, hydraulic motors, pumps, etc. are covered by the warranty, if any, provided separately by their respective manufacturers.

This warranty in all its parts, is extended solely to the original purchaser of the product, is terminated upon any subsequent transfer or sale from or by the original purchaser and extends no third party benefits or rights whatsoever.

The warranty term for any product used in any commercial, custom, for hire or rental application, is limited to six (6) months from the date of delivery of the product to the original purchaser by an authorized H & S dealer.

Polybonded (polyethylene and plywood) panels utilized in H & S Manure Spreaders are warranted, to the original purchaser, to not wear through and the polyethylene overlay to not tear free of the plywood for the functional life of the spreader. This specific warranty on polybonded panels includes only replacement of any defective panel part without any allowance for labor beyond the terms of the general warranty (12 or 6 months), and is further limited to manure spreaders used to spread normal agricultural manure.

This warranty does not include: (1) Any product that has been altered or modified in ways not approved by H & S; (2) Depreciation or damage caused by normal wear, misuse, improper or insufficient maintenance, improper operation, accident or failure to follow the product Operator's Manual recommendations and product decal recommendations; (3) Normal maintenance parts and service; (4) Repairs made with parts other than those available from H & S or performed by anyone other than H & S or a dealer authorized by H & S to sell and/or service the product involved.

To secure warranty service the purchaser must report the product defect to a dealer authorized by H & S to sell and/or service the product involved within the applicable warranty term together with evidence of the warranty start date and make the product available to that dealer within a reasonable period of time.

**THERE ARE NO WARRANTIES WHICH EXTEND BEYOND THE DESCRIPTION ON THE FACE OF THIS WARRANTY. H & S and the companies affiliated with it makes no warranties, representations, or promises, express or implied, as to the performance or freedom from defect of its products other than those set forth above and NO IMPLIED WARRANTY OF MERCHANTABILITY, FITNESS OR FITNESS FOR A PARTICULAR PURPOSE IS MADE. IN NO EVENT WILL THE DEALER, H&S OR ANY COMPANY AFFILIATED WITH H&S BE LIABLE FOR INCIDENTAL OR CONSEQUENTIAL DAMAGES. The ONLY REMEDY the purchaser has in connection with the breach of performance of any warranty on H & S products are those set forth above.**

The selling dealer has no authority to make any representation or promise on behalf of H & S, or to modify the terms or limitations of this warranty in any way.

2/04

**FILL OUT AND MAIL  
IMMEDIATELY TO MAKE  
WARRANTY EFFECTIVE**



## WARRANTY REGISTRATION

Date of Purchase \_\_\_\_\_

Purchaser \_\_\_\_\_ Address \_\_\_\_\_

City \_\_\_\_\_ State \_\_\_\_\_ Zip \_\_\_\_\_

Product \_\_\_\_\_ Model# \_\_\_\_\_ Serial# \_\_\_\_\_

Dealer \_\_\_\_\_ Address \_\_\_\_\_

City \_\_\_\_\_ State \_\_\_\_\_ Zip \_\_\_\_\_

\_\_\_\_\_  
Signature of Original Buyer

**IMPORTANT!**

Tear on dotted line, provide the information requested on the card. The H&S Warranty is valid **“only”** after this card is received and recorded at H&S Mfg. Co. Mail at once. No postage is required in the U.S.A.



NO POSTAGE  
NECESSARY  
IF MAILED  
IN THE  
UNITED STATES

**BUSINESS REPLY MAIL**

FIRST CLASS MAIL Permit No.195 Marshfield, WI 54449

POSTAGE WILL BE PAID BY ADDRESSEE

**H&S Manufacturing Co., Inc.**  
**PO Box 768**  
**Marshfield, WI 54449-9963**

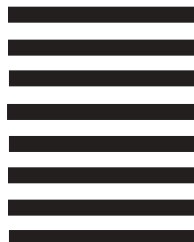

# H&S DEALER PRE-DELIVERY CHECK LIST

## AFTER COMPLETION, DEALER SHOULD REMOVE AND RETAIN FOR RECORDS

After the 170 Grinder-Mixer has been completely set-up, check to be certain it is in correct operating order before delivering to the customer. The following is a list of points to inspect. Check off each item as you have made the proper adjustments and found the item operating satisfactorily.

- Grinder-Mixer was not damaged in shipment. Check for dents and loose or missing parts. Report damage immediately to H&S Manufacturing Co., Inc.
- All bolts and fasteners are tight.
- Mixer has been correctly assembled according to instructions in this manual. Wheel nuts and all other fasteners are tightly secured.
- All grease fittings have been lubricated. The transmission and cyclonic reservoir are filled to proper levels. See Lubrication Chapter of this manual for details.
- Hydraulic pump, motors, hoses and fittings are properly attached.
- Guards and shields are secure.
- Screens fit properly into the mill and the mill cover closes and latches tightly.
- Wheels are properly mounted.
- Tires are inflated to 80 PSI (563 kpa).
- Belts are properly adjusted.
- Rear Drive Chain tension is properly adjusted. See Adjustment Chapter of this manual.
- Discharge auger door operates smoothly.
- Decals are in place and legible.
- Lights and wiring functioning properly if applicable.

**Connect the Mixer onto a proper horsepower 540 RPM or 1000 RPM (if applicable) tractor and attach the PTO. Connect the scale and lights if applicable. Run the Grinder-Mixer and make sure all components operate properly.**

- PTO guard turns freely.
- Hydraulic system does not leak under pressure.
- Electronic Scale (if provided) operates properly.
- Implement and all components are functioning properly.

(Remove Dealer File Copy At Perforation)



# **H&S DEALER PRE-DELIVERY CHECK LIST(CONT.)**

**AFTER COMPLETION, DEALER SHOULD REMOVE AND RETAIN FOR RECORDS**

## **SWINGING INTAKE AUGER (SIA)(if applicable)**

- Guards, shields, and attaching hardware are in place and properly secured.
- SIA lifting, locking and supporting mechanisms function correctly. Counter-balance spring and brake are properly adjusted. See Adjustments Chapter of this manual.
- Transport lock mechanism engages and disengages correctly. Safety locking clip is attached to the transport bracket.
- Hydraulic motor and speed control levers operate properly during operation.
- Decals are in place and legible.

_____	_____
(Dealer's Name)	Model Number
_____	_____
(Signature of Pre-Delivery Inspector)	Serial Number
_____	_____
	(Inspection Date)

## **DEALER DELIVERY CHECK LIST**

This check list that follows is an important reminder of valuable information that should be passed on to the customer at the time this machine is delivered.

Check off each item as you explain it to the customer.

This delivery check list, when properly filled out and signed assures the customer that the Pre-delivery service was satisfactorily performed.

- Explain to the customer that the pre-delivery inspection was made.
- Explain to the customer all the safety precautions they must exercise when operating this unit.
- Explain to customer that regular lubrication is required for proper operation and long life of machine. Show customer the Lubrication Chapter of the Operator's Manual.
- Explain to customer that drain plugs must be installed before operating of grinder- mixer.
- Give the customer Operator's Manual and make sure they read and understand all operating and service instructions.
- Record model and serial number on this page and page 50 of this Manual.
- Have customer sign a completed "Warranty Registration," and mail it promptly.

Date Delivered _____	Dealer's Name _____
_____	By _____
Signature of Original Buyer	

Note: Warranty is not valid until warranty card is completed and returned to H & S Mfg. Co., Inc.

(Remove Dealer File Copy At Perforation)





## SAFETY INFORMATION



**BE  
ALERT!**

**YOUR SAFETY  
IS INVOLVED.**

THIS SYMBOL IS USED THROUGHOUT THIS BOOK WHENEVER YOUR PERSONAL SAFETY IS INVOLVED. TAKE TIME TO BE CAREFUL. REMEMBER: THE CAREFUL OPERATOR IS THE BEST OPERATOR. MOST ACCIDENTS ARE CAUSED BY HUMAN ERROR. CERTAIN PRECAUTIONS MUST BE OBSERVED TO PREVENT THE POSSIBILITY OF INJURY OR DAMAGE.

### **TRACTORS**

This operator's manual uses the term "Tractor" when identifying the power source.

**H & S MANUFACTURING CO. INC.**

# **SAFETY INFORMATION**

## **RECOGNIZE SAFETY INFORMATION**

This is the safety-alert symbol. When you see this symbol on your machine or in this manual, be alert to the potential for personal injury.

Follow recommended precautions and safe operating practices.



## **UNDERSTAND SIGNAL WORDS**

A signal word- DANGER, WARNING, or CAUTION - is used with the safety-alert symbol. DANGER identifies the most serious hazards.

Safety signs with signal word DANGER or WARNING are typically near specific hazards.

General precautions are listed on CAUTION safety signs.



## **FOLLOW SAFETY INSTRUCTIONS**

Carefully read all safety messages in this manual, and all safety signs on your machine. Follow all recommended precautions and safe operating procedures.

Keep signs in good condition. Immediately replace any missing or damaged signs.

# SAFETY INFORMATION

**⚠ WARNING**



**DO NOT CLEAN OR WORK ON THIS MACHINE WITHOUT FIRST DISENGAGING POWER AND SHUTTING OFF TRACTOR ENGINE.**

1494J

**⚠ DANGER**

**SHUT ENGINE COMPLETELY OFF BEFORE ADJUSTING OR SERVICING MACHINE.**

**MACHINE MAY START UNEXPECTEDLY**

**FAILURE TO HEED THIS WARNING MAY RESULT IN PERSONAL INJURY OR DEATH**

3398C

**⚠ WARNING**



**DO NOT REMOVE SHIELDS**

**MOVING PARTS INSIDE**

1494K



**⚠ WARNING**

**DO NOT OPERATE THIS EQUIPMENT IF THIS DECAL IS EXPOSED. REPLACE SAFETY SHIELDS.**

1494A

**H&S**

**GM 170**

82407

**⚠ DANGER**



**ROTATING DRIVELINE CONTACT CAN CAUSE DEATH. KEEP AWAY!**

**DO NOT OPERATE WITHOUT-**

- + ALL DRIVELINE, TRACTOR AND EQUIPMENT SHIELDS IN PLACE.**
- + DRIVELINES SECURELY ATTACHED AT BOTH ENDS.**
- + DRIVELINE SHIELDS THAT TURN FREELY ON DRIVELINE.**

1494L

**⚠ PULL TO STOP**

126-2177

**SHEAR BOLTS**

**REMOVE BROKEN SHEAR BOLT BEFORE REPLACING**

112-11176

**⚠ DANGER**



**MAINTAIN SAFE CLEARANCE FROM ELECTRIC POWER LINES AND AVOID CONTACT WITH ANY ELECTRICALLY CHARGED CONDUCTOR.**

**CONTACT WITH ELECTRIC POWER SOURCES CAN RESULT IN ELECTRICAL SHOCK OR ELECTROCUTION.**

**FAILURE TO HEED THIS WARNING MAY RESULT IN SERIOUS INJURY OR DEATH.**

1494P

# SAFETY INFORMATION

**⚠ WARNING**

DO NOT OPERATE THIS EQUIPMENT IF THIS DECAL IS EXPOSED. REPLACE SAFETY SHIELDS.

32597A

**⚠ WARNING**



**CRUSHING HAZARD**

TO PREVENT SERIOUS INJURY OR DEATH:

KEEP HANDS AND BODY OUT OF HITCH AREA WHEN ATTACHING TOWING VEHICLE.

KEEP BODY CLEAR OF CRUSH POINT BETWEEN TOWING VEHICLE AND LOAD.

KEEP FEET AND LEGS CLEAR FROM UNDER TONGUE AREA IN CASE OF POSSIBLE JACK FAILURE.

82602

**⚠ WARNING**

**HELP AVOID INJURY**

- READ & UNDERSTAND THE OPERATORS MANUAL PROVIDED WITH THIS MACHINE. IF MISPLACED CALL H & S MANUFACTURING AT 715-387-3414 WITH MODEL AND SERIAL NUMBER.
- UNDERSTAND ALL SAFETY WARNINGS AND FUNCTION OF CONTROLS.
- KEEP SAFETY DEVICES IN PLACE AND WORKING.
- KEEP YOURSELF AND OTHERS WELL CLEAR OF MOVING PARTS.
- DISCONNECT ALL POWER BEFORE SERVICING OR CLEANING THIS MACHINE.
- DO NOT EXCEED 25 MPH

72203A

**⚠ WARNING!**



**KEEP CHILDREN AWAY AT ALL TIMES!**

2495



**⚠ WARNING**

**DO NOT GO NEAR LEAKS**

- High pressure oil easily punctures skin causing serious injury, gangrene or death.
- If injured, seek emergency medical help. Immediate surgery is required to remove oil.
- Do not use finger or skin to check for leaks.
- Lower load or relieve hydraulic pressure before loosening fittings.

11590



**⚠ WARNING**

**STAY CLEAR OF DISCHARGE AUGER**

82987A

**⚠ DANGER**



**NO STEP-STAY CLEAR**

9194A

# SAFETY INFORMATION

	<p style="margin: 0;"><b>⚠ WARNING</b></p> <p style="margin: 0; text-align: center;">STAY CLEAR OF AUGER EXTENSION HINGE AREA</p>
---	---

	<p style="margin: 0;"><b>⚠ DANGER</b></p> <p style="margin: 0; text-align: center;"><b>STAY CLEAR</b> KEEP HANDS AND FEET AWAY FROM AUGER AT ALL TIMES FAILURE TO HEED THIS WARNING MAY RESULT IN PERSONAL INJURY OR DEATH</p>
---	--

	<p style="margin: 0;"><b>⚠ DANGER</b></p> <p style="margin: 0; text-align: center;"><b>STAY CLEAR</b> KEEP HANDS AND FEET AWAY FROM AUGER AT ALL TIMES FAILURE TO HEED THIS WARNING MAY RESULT IN PERSONAL INJURY OR DEATH</p>
---	--

	<p style="margin: 0;"><b>⚠ WARNING</b></p> <p style="margin: 0; text-align: center;">STAY CLEAR ROTATING PARTS INSIDE</p>
--	---

	<p style="margin: 0;"><b>⚠ WARNING</b></p> <p style="margin: 0; text-align: center;">STAY CLEAR ROTATING AUGER BEHIND THIS PANEL</p>
---	--

	<p style="margin: 0;"><b>⚠ DANGER</b></p> <p style="margin: 0; text-align: center;"><b>NEVER ALLOW RIDERS ON THIS MACHINE</b></p>
---	---

<p style="margin: 0;"><b>OPEN</b></p> 	<p style="margin: 0;"><b>CLOSE</b></p> 
---	--



# SAFETY INFORMATION



**⚠️ WARNING**

**STAY CLEAR  
KEEP HANDS OUT  
OF SUPPLEMENT  
HOPPER**

82907G

**⚠️ WARNING**

**DO NOT STEP UP ON  
MACHINE WHILE IN  
OPERATION**

82907I



**⚠️ DANGER**

**KEEP OUT**

**DO NOT ENTER  
TANK. KEEP COVER CLOSED.  
FAILURE TO HEED THIS  
WARNING MAY RESULT IN  
PERSONAL INJURY OR DEATH**

82907F

**⚠️ WARNING**

 540	Operate only with 540 RPM PTO. DO NOT operate with 1000 RPM PTO. Overspeed can cause death, injury or damage.
 1000	



093020



135

85

125

75

**CYCLONE COVER**

OPEN
CLOSE



82907K

115

65



**OPERATOR'S MANUAL  
IS LOCATED BEHIND  
THIS SHIELD**

82907J

105

55

95

## TRACTORS:

This operators manual uses the term “Tractor” when identifying the the power source.



# WARNING

## TO PREVENT SERIOUS INJURY OR DEATH

BEFORE YOU ATTEMPT TO OPERATE THIS EQUIPMENT, READ AND STUDY THE FOLLOWING INFORMATION. IN ADDITION, MAKE SURE THAT EVERY INDIVIDUAL WHO OPERATES OR WORKS WITH THIS EQUIPMENT, WHETHER FAMILY MEMBER OR EMPLOYEE, IS FAMILIAR WITH THESE SAFETY PRECAUTIONS.

KNOW HOW TO STOP MACHINE BEFORE STARTING IT.

If the machine becomes clogged or for servicing, Stop the tractor engine, remove ignition key and allow all mechanisms to stop. Before cleaning or working on the machine, detach the PTO shaft, and completely disengage the tractor hydraulics.

**DO NOT** attempt to perform maintenance or repair with tractor running, PTO and hydraulic hoses connected to the tractor.

**DO NOT** step up on machine at any time while in operation.

**DO NOT** allow minors to operate or be near the machine.

**DO NOT ALLOW PERSONNEL OTHER THAN THE QUALIFIED OPERATOR NEAR THE MACHINE.**

**STAY CLEAR** of discharge auger when in operation.

Keep hands, feet, and clothing away from all moving parts when the Grinder-Mixer is in operation.

Loose or floppy clothing should not be worn by the operator.

Be sure the machine is clear of people, tools, and other objects before engaging PTO.

Do not step over PTO shaft: Stay clear of PTO at all times.

**NEVER** start the Grinder-Mixer until all guards and safety shields are secured in place.

Never operate Grinder-Mixer with a PTO speed greater than the recommended PTO RPM.

**STAY CLEAR** of hydraulic lines, they may be under extreme pressure or heat.

**NEVER** open or plug the water drain holes with the Mixer running.

H&S Mfg. Co. always takes the operator and their safety into consideration and guards exposed moving parts for their protection. However, some areas cannot be guarded or shielded in order to assure proper operation. In addition, the operators manual and decals on the machine itself warn you of further danger and should be read and observed closely.

**Study The Above Safety Rules**  
**ATTENTION - BE ALERT - YOUR SAFETY IS INVOLVED**

# CAP SCREW TORQUE VALUES

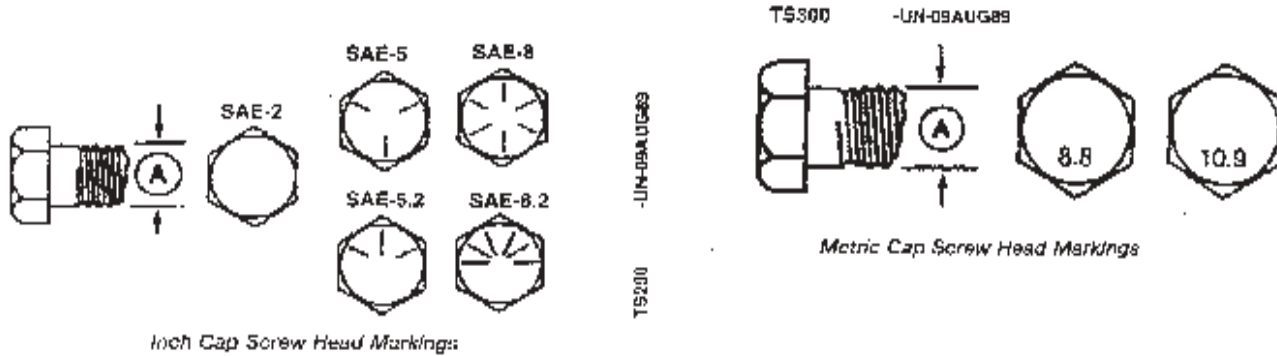

## INCH CAP SCREW TORQUE VALUES

## METRIC CAP SCREW TORQUE VALUES

Bolt Diameter Wrench (A) Size	Cap Screw Grade					
	SAE 2		SAE 5		SAE 8	
	N-m	lb.-ft	N-m	lb.-ft	N-m	lb.-ft
1/4" 7/16"	7 (5)	11 (8)	16 (12)			
5/16" 1/2"	14 (10)	23 (17)	33 (24)			
3/8" 9/16"	24 (18)	41 (30)	54 (40)			
7/16" 5/8"	41 (30)	68 (50)	95 (70)			
1/2" 3/4"	61 (45)	102 (75)	142 (105)			
9/16" 13/16"	88 (65)	142 (105)	203 (150)			
5/8" 15/16"	122 (90)	197 (145)	278 (205)			
3/4" 1-1/8"	217 (160)	353 (260)	495 (365)			
7/8" 1-3/16"	274 (205)	553 (415)	800 (590)			
1" 1-1/2"	332 (245)	848 (625)	1193 (880)			
1-1/4" 1-7/8"	665 (490)	1492 (1100)	2393 (1765)			

Bolt Diameter Wrench (A) Size	Markings on Cap Screw Heads			
	8.8		10.9	
	N-m	lb.-ft	N-m	lb.-ft
5 mm 8 mm	6 (4.5)	9 (6.5)		
6 mm 10 mm	10 (7.5)	15 (11)		
8 mm 13 mm	25 (18)	35 (26)		
10 mm 16 mm	50 (37)	75 (55)		
12 mm 18 mm	85 (60)	130 (97)		
16 mm 24 mm	215 (159)	315 (232)		
20 mm 30 mm	435 (321)	620 (457)		
24 mm 36 mm	750 (553)	1070 (784)		
30 mm 48 mm	1495 (1103)	2190 (1611)		



**CAUTION:** Use only metric tools on metric hardware. Other tools may not fit properly. They may slip and cause injury.

DO NOT use these values if a different torque value tightening procedure is listed for a specific application. Torque values listed are for general use only. Check tightness of cap screws periodically.

Shear bolts are designed to fail under predetermined loads. Always replace shear bolts with identical grade. Fasteners should be replaced with the same or higher grade. If higher grade fasteners are used, these should only be tightened to the strength of the original.

Make sure fastener threads are clean and you properly start thread engagement. This will prevent them from failing when tightening.

Tighten plastic insert or crimped steel-type lock nuts to approximately 50 percent of amount shown in chart. Tighten toothed or serrated-type lock nuts to full torque value.



# **PREPARING FOR OPERATION**

## **TRACTION CONNECTIONS**

### **PTO**

Fasten the Grinder-Mixer to the tractor drawbar with a hitch pin with safety locking device, and attach the Grinder-Mixer PTO to the tractor PTO shaft locking it into position.

1. Maintain a straight alignment between the grinder-mixer and the tractor.
2. Maintain a 15-1/2" distance between the lock on the tractor PTO and hole on grinder-mixer hitch for a 540 RPM machine.
3. Maintain a 17" distance between the lock on the tractor PTO and hole on grinder-mixer hitch for a 1000 RPM machine.
4. Maintain a distance of 6"- 12" between the top of the tractor drawbar and the center of the tractor PTO. An 8" distance is standard.



### **Hydraulics**

The GM 170 requires a 4 hose hook-up; 2 hoses for the discharge auger lift, and 2 hoses for the discharge auger rotation.

## **PREPARING MIXER**

- \* Properly lubricate the grinder-mixer, checking the transmission and cyclonic reservoir oil levels, and filling if necessary before operating the grinder-mixer.
- \* All drain plugs must be properly installed and secured.
- \* Follow the procedures outlined in the Operation Chapter of this manual for installing the mill screen.
- \* The tank lid and the discharge auger door must be closed and the cyclone cover must be open.
- \* Start the tractor, engage the PTO at idle speed and increase the rpm's until the grinder-mixer is running at the rated PTO speed. Begin the grinding process.

# SET-UP & ASSEMBLY

## WHEELS & TIRES

The Grinder-Mixer is shipped without the rims and tires installed on the axle hubs. Install the rims and tires, and torque the wheel nuts to 90 ft-lb (124 N-m). Inflate the 12.5L x 15 - 20 ply tires to 80 PSI (563 kpa).

## DRAIN PLUGS & DRAIN COVER

When the Grinder-Mixer is delivered, the drain plug on the back plate of the transfer auger will be in the storage position. See the diagram below for the storage position. When the GM 170 is ready for delivery, install the drain plug in the back plate of the transfer auger. If the mixer is equipped with a Swinging Intake Auger (SIA), the drain plug will also be in the storage position. Upon delivery, also install the drain plug in the drain hole in the bottom of the SIA attachment.

**IMPORTANT:** Never open or plug the water drain holes with the mixer running.

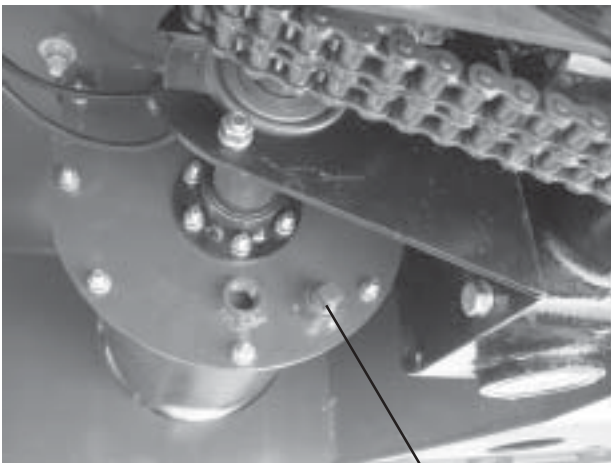

Transfer Auger Drain Plug In Storage Position.



SIA Drain Plug In Storage Position.

## STORAGE

**IMPORTANT:** If the GM 170 is stored outside, the water drain holes must be left unplugged. Before the mixer is going to be operated, re-install the plugs. After a rain, check the mill, mixing tank, and augers for water accumulation before operating the mixer. As necessary, drain the water before using the mixer.

**NOTE:** After water has been drained from the mixer, it is advisable to run the GM 170 while empty for a period of time in an attempt to dry the mixer before grinding to eliminate any sticking of material and possible plugging.

# TRANSPORTING

## SMV BRACKET & REFLECTORS

The grinder-mixer is equipped with a SMV bracket. Red reflector strips are located on the rear of the tank and on the SIA (if applicable).



## TRANSPORT LIGHTING

An optional highway transport lighting kit is available.



# OPERATION

## EMERGENCY SHUTDOWN

In an emergency or in case a foreign object enters the mill inlet, stop mixer operation immediately by disengaging the tractor PTO.

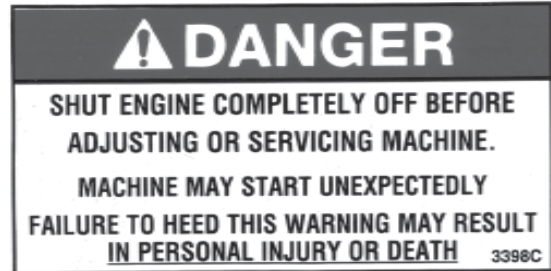

## GENERAL INFORMATION

Check entire unit carefully before first operation. Tighten bolts and set screws that might have come loose in shipping. Lubricate as explained in the Lubrication Chapter in this manual.

**NOTE:** *These procedures must be done before grinding;*

- 1.) *Grinder mill door is closed.*
- 2.) *The collector cover is open,*
- 2.) *The tank lid is closed,*
- 3.) *The unloading auger shut-off door is closed.*

Operate the mixer on level ground for uniformity of mix. Maintain a straight-line alignment between the tractor and mixer to prolong the life of the drive line components.

Maintain the tractor rated PTO speed which produces a mill cylinder speed of 2700 RPM, to obtain the most efficient grind. Do not exceed a cylinder speed of 3000 RPM. Before grinding, the unloading auger shut-off door must be closed.

Add supplements after a small amount of feed has been ground, then dry granular materials.

**NOTE:** *Do not grind feed with high moisture content. This may cause plugging. Abnormally damp crops will not feed or mix well.*

Grinding should be stopped when the feed in the windows begins to drop.

**IMPORTANT:** *Overfilling the mixing tank will place unnecessary stress on the drive line components. Keep the tank lid closed and properly latched so that if the tank is accidentally overfilled, the lid can pop open and release the feed inside the tank.*

The two full-length windows on the tank are calibrated with numbers representing bushels of ground feed.

**NOTE:** *Optional models of electronic scales are available for accurate weight measurements and rations.*

Stop the tractor and disengage the mill/blower drive sheave pin after grinding. Start the tractor and allow the mixer to continue running for several minutes to thoroughly mix the ground feed. Allow the mixer to continue running during transport, disengaging the PTO on corners or turns.

**IMPORTANT:** *When transporting the mixer and mixing, disengage the tractor PTO before turning corners to prevent damage to the PTO driveline.*

# OPERATION (cont.)

## CAPACITY

The GM 170 mixing tank capacity is 170 cubic feet or 135 bushels by volume. The tank will hold approximately 6000 to 7000 lbs of ground feed consisting of average weight corn, small grain and/or concentrates. More or less weight (per tank) is possible, depending upon whether the material that is being ground is lighter or heavier than average. Grinding capacity of the mill will vary due to the type of material being ground, the moisture content of the material, the size screen used, and the horsepower of the tractor used to operate the mixer.

The mixer is designated for operation by a 50 to 115 hp (28 to 86 kW) 540 RPM tractor or by a 50 to 145 hp (38 to 109 kW) 1000 RPM tractor.



## 540/1000 RPM PTO DRIVE

The H&S GM 170 grinder-mixer features a 540 drive as standard equipment for use with tractors up to 115hp (86kW).

An optional 1000 RPM drive is available for use with tractors up to 145hp (109 kW).



## MILL & BLOWER

### Drive Sheave

The mill/blower can be engaged or disengaged by the positioning of a pin on the sheave.

To disengage the mill/blower, grasp the pin handle, pull it forward and rotate it onto the L-shaped bracket.

**IMPORTANT:** When starting the Grinder-Mixer, engage the tractor PTO at a slow idle speed. Advance the throttle of the tractor to the rated PTO speed.

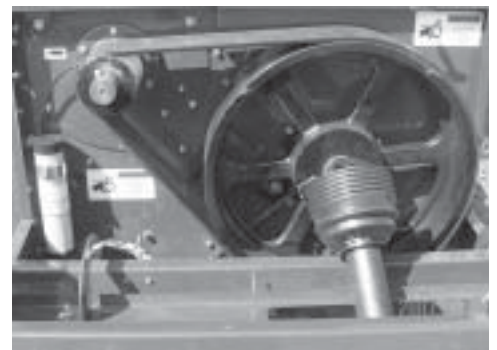

### Mill & Blower Operation

Material enters the cylinder chamber through the mill inlet and is drawn into the cylinder by a vacuum below the cylinder. The vacuum below the cylinder is obtained by the physical location of the blower Inlet below the cylinder.

The 21" cylinder is composed of sixty-six swinging hammers which are equally divided among three rows around the cylinder. As the cylinder rotates at the recommended speed of 2700 RPM, the hammers grind the material and force it through the screen. Once through the screen, the ground material drops down to the transfer auger and is conveyed to the mixing tank. Light-weight chaff or dust is drawn into the blower inlet and forced by the blower up into the collector where it is refined and separated. Heavy particles are directed back down into the transfer auger and conveyed to the mixing tank.

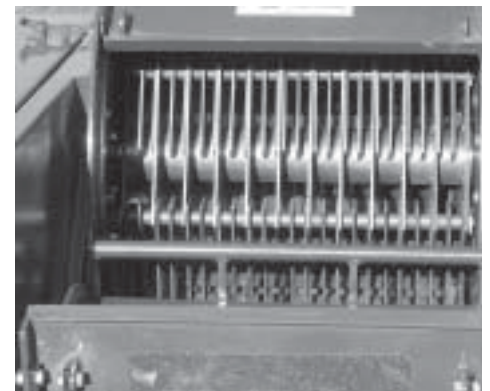



# OPERATION (cont.)

## SELF-CONTAINED HYDRAULIC SYSTEM

### Hydraulic System

The mixer has a self-contained hydraulic system featuring hydraulic motor operated discharge augers and an optional hydraulic motor operated swinging intake auger attachment. The self-contained hydraulic system is composed of a pump, flow control with pressure relief, cyclonic reservoir and oil filter.



**Note:** When operating at cold temperatures, allow the hydraulic oil in the self-contained system to warm up at tractor idle speed with the PTO running prior to grinding.



### Pressure Relief Valves

Pressure relief valves on the variable speed controls for the Swinging Intake Auger (SIA) if applicable, and discharge auger system provide overload protection for the hydraulic system. The relief valves will permit pressure build-up to a factory set value of 3200 PSI. The self-contained hydraulic system operating pressure range is normally 500 to 2000 PSI. If the SIA is stopped by a malfunction or overloading, the pressure will build up to the factory set cut-off pressure and the relief valve will open allowing oil to flow directly through the flow control and continue to the flow control for unloading augers which will continue to function. If one of the hydraulic motors of the unloading auger system is stopped by a malfunction of the component it is driving, the pressure will build-up to the factory set cut-off pressure and the relief valve will automatically stop flow throughout the entire hydraulic system. After the problem is corrected, the relief valve will automatically reset and restore oil flow to the system.



### Hydraulic Pump/Motor Drive

The GM 170 has a double sheave on the end of the main drive shaft which is connected by a double banded belt to the hydraulic pump. The pump is belt driven directly off the main drive shaft which is coupled by the telescoping drive to the tractor PTO shaft. Overload protection for the hydraulic pump is provided by a self-adjusting spring tightener.

**IMPORTANT:** Stop mixer operation if drive belt slipping is detected.



# OPERATION (cont.)

## Discharge Auger System

Ground feed from the mixing tank is discharged by an auger system consisting of three hydraulically motor driven augers that are connected in series so that all augers are synchronized as well as started and stopped together. If any motor malfunctions, the movement of material through the augers will stop immediately. The discharge auger unloads material to any point within a 300 degree radius. The length of the unloading auger is approximately 12 feet, without any extensions. By adding a 3' or 6' folding extensions, the length can be increased. A transport cradle is provided for holding the unloading auger in position during transport.



Shown with 6' folding extension

## Needle Valves

An adjustable needle valve is provided on each hose of the discharge auger rotation to control the speed of auger swing to provide smooth rotation. Needle valves are located at the rear of the machine by the hydraulic rotation motor. See the Adjustment Chapter of the manual for adjustment details.



## Discharge Auger Door & Variable Speed Valve

A variable speed valve with a pressure relief controls the hydraulic motors which operate at a single constant speed determined by the speed of the tractor PTO, or at a variable speed determined by the valve. A discharge auger shut-off door is provided to regulate the amount of feed passing into the discharge auger.

***NOTE:*** Always activate the hydraulic variable speed control valve to engage the discharge augers before opening the discharge auger shut-off door. When the mixing tank has been unloaded, close the discharge auger shut-off door then shut-off the hydraulic variable speed control valve .



# **OPERATION (cont.)**

## **HYDRAULIC OPERATED ATTACHMENTS**

### **Swinging Intake Auger (SIA)**

An optional hydraulic drive Swinging Intake Auger (SIA) attachment conveys material into the mill. The intake auger can be swung in and locked against the mixer tank support brace for transporting, or swung out and locked at any point. Operating height of the infeed hopper can be raised or lowered and held in position using the rope mechanism. The attachment is spring counterbalanced to help with lifting. The right portion of the infeed hopper folds in to reduce overall width for transporting.



### **SIA Variable Speed Control Valve**

Speed control handles are provided for regulation of the speed of conveyor auger rotation. Movement of any one of the three mechanically interconnected handles enables stopping and starting auger rotation as well as regulating the feeding rate of material being fed into the mill hopper. Two other convenience features on the SIA are an enclosed wind and grain shield, which is located over the discharge end of the SIA trough, and a water drain plug which is located in the bottom of the trough infeed hopper.



## **GRAVITY FEEDER**

The standard equipment gravity feeder is a stationary hopper with no moving or running parts. Material to be ground is dumped into the hopper and slides directly into the mill inlet. A combination steel/rubber splash plate prevents the material which is being fed from being kicked out by the mill cylinder.



## **MAGNETS**

Two heavy-duty 4" x 18" magnets located in the gravity feed hopper remove any metal that may accidentally mix with the material entering the mill.





## OPERATION (cont.)

### SCREENS

Uniformity of grinding is a factor of mill speed, condition of the hammers, and sharpness of the screen. The efficiency of the mill will also decrease if the holes of the screen are badly worn. If grinding fineness is deteriorating, the screen should be rotated to place the sharp holes edges against the direction of the cylinder rotation or the screen should be replaced. The GM 170 can be fitted with numerous screens that are available with various size holes to accommodate different material and grinding requirements. A screen storage rack is provided on the left side of the mixer.

**NOTE:** *If a screen is correctly installed, it should fit tight against the mill throat plate and butt tightly against the mill frame hood sheet when the mill screen cover is closed and securely latched.*

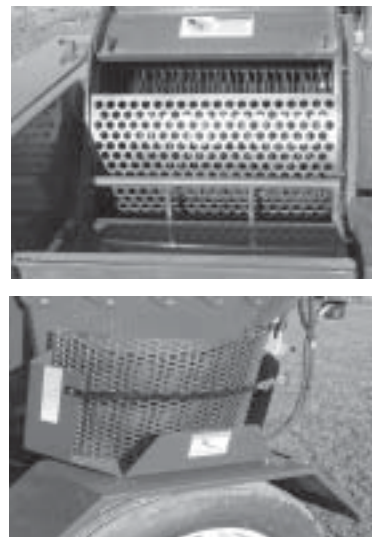

The listing below are only suggested hole size recommendations for different materials;

Fine Grind	Small Grains; 1/8", 3/16"
Medium Grind	Small Grains; 3/16", 1/4", 5/16"
Coarse Grind	Small Grains; 3/8", 1/2", 5/8"
Fine Grind	Shelled Corn; 1/8", 3/16", 1/4", 5/16"
Medium Grind	Shelled Corn; 3/8", 1/2", 5/8"
Coarse Grind	Shelled Corn; 3/4", 1"
Fine Grind	Ear Corn; 1/4", 5/16", 3/8"
Medium Grind	Ear Corn; 1/2", 5/8"
Coarse Grind	Ear Corn; 3/4", 1", 1-1/4", 1-1/2"

### SUPPLEMENT HOPPER

The cover on the supplement hopper is spring-loaded to hold it in either the open or closed position. A bag guard is provided to prevent containers from being accidentally drawn into the transfer auger. A flip-over bag breaker allows easy opening of supplement bags.

**NOTE:** *Liquids, such as molasses, should not be poured into the grinder-mixer.*



### TANK LID

The lid on top of the mixing tank features spring-loaded latches which enables it to be forced open by overflowing material should the tank accidentally become filled beyond capacity. The tank lid will open, allowing the ground feed to spill-out to prevent damage to the mixing auger and drive components.

**IMPORTANT:** *Stop mixer operation if the tank lid is forced open. Before restarting to grind or mix, the tank lid must be closed and the latches properly adjusted.*



# **OPERATION (cont.)**

## **OVERLOAD PROTECTION**

### **Main Drive**

The GM 170 is furnished with a 5/16 x 1" Grade 5 shear bolt protecting the transfer auger drive shaft, transmission and mixing auger. When the shear bolt fails, the transfer auger and mixing auger will stop turning. Check the rear chain tightener for proper tension if this bolt shears.



### **Transfer Auger**

The 1/4" x 1-1/4" Grade 5 transfer auger shear bolt is accessible only through the mill cover. This shear bolt protects the auger flighting. The transfer auger will stop rotating even though the auger/transmission drive shaft will continue to rotate if this shear bolt fails.



**IMPORTANT:** Stop mixer operation when either shear bolt fails.

## **UNPLUGGING**

**IMPORTANT:** When plugging is detected, stop mixer operation.

### **Mill, Mill Drive and Mixing Tank**

Overfeeding of the mill and/or the mill inlet can result in plugging, thus slipping of the miller/blower drive belt, shearing of either the auger/transmission shear bolt, or the transfer auger shear bolt. Abnormal crop conditions would include crops with high moisture content or crops that are too light or bulky which would not feed properly.

### **Overfeeding**

If plugging develops from overfeeding, the tractor will choke down and even stall. To remove the plugging proceed as follows:

1. Shut the tractor off, remove key, disengage the PTO, detach the PTO and hydraulic hoses from the tractor.
2. Shut off the feeder attachment.(If applicable)
3. Open the mill screen cover, remove the screen and allow the material to fall down into the transfer auger or remove material if the transfer auger is overloaded, close mill cover.
4. Disengage the mill/blower drive sheave pin.
5. Start the tractor and engage the PTO at slow speed to convey the material into the Tank.
6. Shut the tractor off and disengage the PTO.
7. Open the mill screen cover, replace the mill screen, close mill cover, engage the mill/blower drive sheave pin, and restart the tractor and PTO.
8. Bring the mill up to proper running speed and restart the feeder attachment(if applicable). If the condition of the crop remains the same, reduce the feeding speed to avoid overfeeding.

# OPERATION (cont.)

## BLOWER INLET & OUTLET

**NOTE:** *The collector cover must always be open while grinding.*

Plugging in the blower inlet or outlet can be seen by the abnormal amount of dust particles in the air around the top of the collector, and/or the visible presence of dust in the mill throat area and/or a reduced air discharge at the top of the collector. If plugging is detected, proceed as follows:

### Blower Inlet

1. Stop the tractor engine, remove ignition key, allow all mechanisms to stop and disengage PTO.
2. Open the mill screen cover and remove the screen.
3. Inspect the blower inlet opening and remove any build-up.

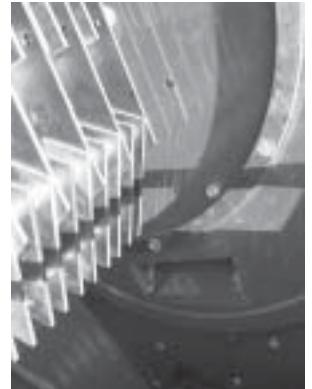

### Collector

4. If there is no air coming out the top of the collector, the plugging is in the discharge side (blower outlet). Remove and clean out the tube connected to the blower outlet. Climb the ladder and check the inside of the collector. If the cyclone is plugged, remove the pipe below the cyclone and dislodge the plugging material.
5. After the plugging has been removed, replace the screen, close and latch the mill screen cover and attempt to resume grinding.



## OPERATION (cont.)

### MILL/BLOWER DRIVE BELT SLIPPAGE

Overload protection for the mill and blower components is provided by an 8 “A” section drive belt, which connects the mill/blower driven sheave to the drive sheave. The mill and blower will gradually slow down without much reduction in tractor PTO speed if plugging develops from mill/blower drive belt slippage, and stop turning the mill/blower drive shaft if plugging or breakdown occurs in the mill or blower areas. Follow steps 1 through 5 from the previous page to remove the plugging. After the plugging has been removed, shut the tractor off, disengage the PTO, and adjust the drive belt tension to the proper tension(see [Adjustment](#) Chapter). Re-start the tractor and PTO, bring the mill cylinder up to proper operating speed and resume grinding.



**IMPORTANT:** Stop mixer operation if drive belt slipping is detected.

### SHEAR BOLTS

Blockage in the mixer may cause the tractor to stall. Shut down the tractor and mixer, disconnect the PTO, and proceed as follows:

1. Open the mill screen cover and clean material out of the mill/cylinder and transfer auger area.
2. Check the auger/transmission shear bolt to determine if it has sheared. Rotate the mill drive sheave by hand to turn the sprocket, shaft and transfer auger. If the shaft does not turn, follow the shear bolt replacement procedures according to the [Service](#) Chapter in this manual.
3. If the transfer auger does not turn, the transfer auger shear bolt has failed. Refer to the [Service](#) Chapter in this manual for shear bolt replacement information.
4. After the shear bolts have been replaced, attempt to rotate the entire assembly. If rotation, in either direction, is not possible, proceed to step 5. If the sprockets and transfer auger turn but the mixing auger does not turn, proceed to step 6.
5. Check for a broken chain, drive sprocket or driven sprocket or for sheared keys which hold the sprockets. Replace any damaged parts.
6. If the items in step 5 are not at fault, remove the transmission drive chain and attempt to rotate the transmission input shaft. If the input shaft turns freely, internal transmission component failure is probable. Remove the transmission and take it to your nearest dealer for repair.

After the cause of the plugging has been corrected, restore all components, guards and shields before resuming operation according to the [Service](#) Chapter in this manual.

# ADJUSTMENTS

## MILL/BLOWER DRIVE

The combination mill/blower driven sheave is connected from the main drive sheave by an 8" "A" section banded drive belt. Adjusting bolts are provided to align the drive sheave with the driven sheave as well as to adjust the drive belt tension.

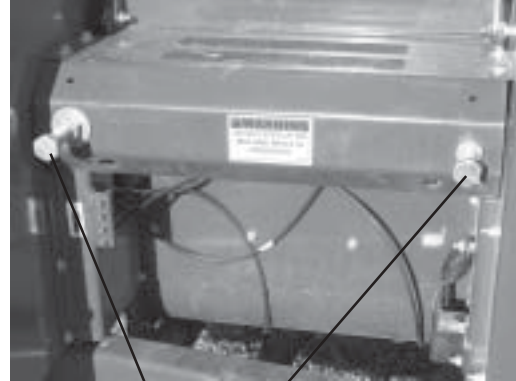
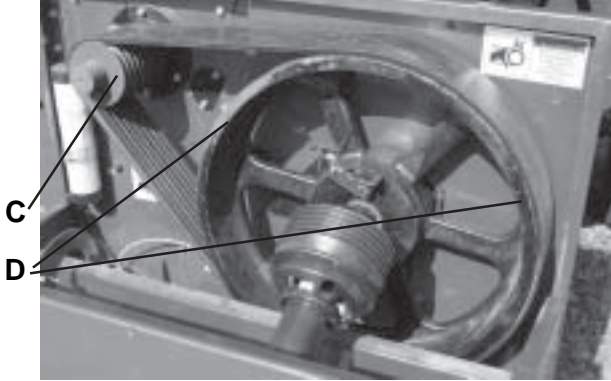

### Sheave Alignment

To align the combination mill/blower driven sheave with the drive sheave, proceed as follows:

1. Loosen both of the bolt/nut (A & B) assemblies on the main drive shaft.
2. Place a straightedge across the faces of both sheaves (C & D) to check alignment.
3. Adjust the nut on the left bolt assembly (A) and the bolt on the right side assembly (B) to bring the drive sheave into alignment with the driven sheave.
4. After proper alignment is obtained, check and adjust drive belt tension.

### Belt Tension

To adjust mill/blower drive belt tension, proceed as follows:

1. Check the drive belt tension initially by measuring the amount of belt deflection at the midway point between the sheaves while applying 60 lbs. of force at the midway point.
2. Adjust the nut on the left bolt assembly (A) clockwise to decrease deflection (increase tension) and adjust the right side bolt assembly (B) an equal number of turns counterclockwise to keep drive sheave in alignment with driven sheave. Adjust both sides until the deflection measures 3/8" (10 mm).
3. After proper tension is obtained, check for correct sheave alignment, retighten the lock nut on the right side bolt.

**NOTE:** A new drive belt should be adjusted for an initial tension of 3/8" (10 mm) deflection with an applied pressure of 80 lb. (360 N). Refer to the Service chapter of this manual for new belt installation procedures.



## **ADJUSTMENTS (cont.)**

### **FRONT DRIVE CHAIN**

The transfer auger/transmission shaft is driven by a sprocket which is connected by the front drive chain to a sprocket on the main drive shaft. The front chain tension is self-adjusted by a spring-loaded idler and does not require adjustment. The chain should be inspected periodically for signs of wear.

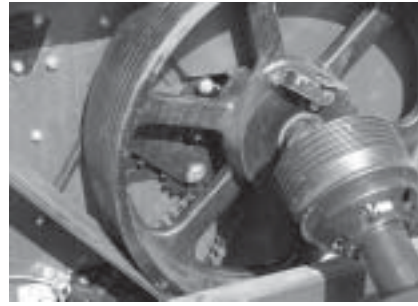

### **TRANSMISSION DRIVE (REAR) DRIVE CHAIN**

The transmission input sprocket is linked by the rear drive chain to a sprocket on the end of the transfer auger drive shaft. Chain tension can be adjusted by appropriate positioning of an idler sprocket which is attached to an adjustable bracket. Access to the idler and bracket is obtained from under the machine. Chain tension should be adjusted and maintained at a ¼" (6 mm) deflection on the strand of chain opposite the idler sprocket.

**NOTE:** *Rear chain tension should be checked periodically and properly adjusted to prevent wear and excessive noise.*



### **SWINGING INTAKE AUGER ATTACHMENT**

#### **SIA Brake Tension**

A brake lever adjusts the hold and horizontal position of the swinging intake auger attachment. The brake mechanism consists of a cam-type lever-activated mechanism which is connected to a band around the attachment pivot. An adjustment bolt on the opposite end of the lever, can be turned in to tighten, or out to loosen the band around the pivot. The bolt should be adjusted so when the brake lever is at a right angle to the pivot, there is no binding or restriction when the auger is swung. When the brake lever is straight out, there should be tight clamping around the pivot and the auger is firmly held in place.



#### **SIA Counterbalance Spring Tension**

The Swinging Intake Auger (SIA) attachment is spring counterbalanced to facilitate lifting the attachment. There are multiple holes in the spring attachment bracket to select the appropriate SIA lift tension. The spring should provide enough tension to conveniently raise the SIA and still allow the SIA to remain stationary when the intake hopper end is lowered to the ground.



## ADJUSTMENTS (cont.)

### MILL SCREEN COVER LATCHES

Over-center handle latches are used to secure the mill cover tightly closed while the mill is being operated.

Lock nuts on the bolts of the latches are used to adjust latching tension. This tension should be adjusted and maintained so that some force has to be applied on the handles to lock and unlock them. Both latch mechanisms should be adjusted equally.



### NEEDLE VALVES

An adjustable needle valve is provided on each hose of the discharge auger rotation to control the speed of auger swing to provide smooth rotation. Needle valves are located at the rear of the machine by the hydraulic rotation motor. Unlock the set screw on the valve - adjust each valve by dialing it left or right to decrease or increase auger rotation speed. After the speed has been set, lock the set screw down.



### TANK LID

The tank lid on top of the mixing tank is designed to be self-unlatching in the event that the mixing tank accidentally becomes overfilled. The latching mechanism should be properly adjusted by the latch nut to maintain proper tension on the lid to keep it closed and weather-tight, but still allow it to be forced open from the inside of the tank by overflowing material. If the latch handle can be pulled straight up approximately ½" (12 mm), completely compressing the spring, tension is correct.

**IMPORTANT:** *The latch springs should never be completely compressed when the handle is all the way down or the lid will not open during over filling.*



### 12' DISCHARGE AUGER

#### Transport Cradle

The unloading auger must always be moved to and set into the transport cradle before the mixer is transported. If the auger does not set in the cradle, adjust the stop bolt on the vertical rotating auger at the rear of the machine.



#### 3' & 6' Discharge Auger Extensions

The 3' and 6' discharge auger extensions fold back and lock into position with a safety lock pin. If the main pin does not line up with the hole on the bracket of the standard 12' auger, loosen the bolts and adjust the bracket.



# LUBRICATION

## GENERAL INFORMATION

**IMPORTANT:** *The GM 170 must be properly lubricated, the transmission and cyclonic oil reservoir must be filled to the proper oil levels before it can be operated.*

**IMPORTANT:** *Catch and dispose of fluid per local waste disposal regulations whenever service is performed on hydraulic components (valves, cylinders, hoses, etc.) or transmission.*

## TRANSMISSION OIL LEVEL

**NOTE:** *Check the fluid level in the mixer transmission periodically by removing the plug located on the transmission. Requirements: 1-1/2 U.S. Pints (0.7 liters) of SAE #140 Gear Lube.*

Check the transmission occasionally for oil drips and dust accumulation around the seals. Oil drips or dust accumulation indicate that seals are leaking.

Water is present in the oil if the oil is tan in color and foams excessively. Drain and replace the lubricant immediately.

**NOTE:** *Fill the transmission gearbox to the bottom of the inspection plug hole - Do not overfill!*

## OILING

The GM170 utilizes an automatic oiling system to lubricate the #60 main drive chain and the double #50 transmission drive chain. Any time that the discharge auger is raised, a specified amount of oil is sent to the brushes on each of the chains. The oiler is adjustable to set the amount that is being discharged. The rotating chain on the discharge auger should be lubricated every 5 hours using a good grade of lubricant. Spray the entire chain on the center of the rollers.

## CYCLONIC OIL RESERVOIR

Check the cyclonic oil reservoir daily. Oil level should be between Max/Min level marks. Fill as needed using Exxon Nuto H46 or Equivalent.



# LUBRICATION (cont.)

## GREASING

**NOTE:** Grease all fittings at the intervals of operation listed, before and after storing the unit, and as otherwise listed. Use a good grade of Lithium-base grease.

Wipe dirt from the fittings before greasing to prevent the dirt from being forced into the bearing or pivot. Grease should come out around the shaft on sleeve type bearings. To minimize dirt build-up, avoid excessive greasing.

## GREASE FITTING LOCATIONS

### **Grease Every 10 hours (or Daily)**

1. Telescoping PTO Drive (3 zerks)
2. Front & Rear Mill Bearings - (2 zerks - remote in Grease Bank under main shaft shield)
3. Main Shaft Slider Bearings - (2 zerks - remote in Grease Bank under main shaft shield)
4. Transfer Auger Front Bearing(1 zerk - under mill cover on front of auger)
5. Transfer Auger Rear Bearings(2 zerks - remote on rear of frame)
6. Transmission Output Shaft Collar(1 zerk - remote on rear of frame)
7. Transmission Input Shaft Bearing(1 zerk - remote on rear of frame)
8. Top of Mixing Auger(1 zerk - under top of tank cover)
9. Unloading Auger Rotating Pivot/Collar(4 zerks - 2 on the top of the collar & 2 on the bottom of the collar)
10. Unloading Auger Vertical Pivot/Collar(4 zerks - 2 on each side of the pivot)
11. Unloading Augers(2 zerks - 1 on the top of vertical section auger & 1 at the end of the auger discharge spout)
12. Flywheel (1 zerk - under front main cover)

### **Attachments - As Applicable**

13. SIA Upper Pivot Bearing(1 zerk)
14. SIA Lower Pivot Bearing(1 zerk)

### **Grease Each Time a Bolt is Sheared or at least Once a Year**

15. Auger/Transmission (Main) Shear Device(1 zerk - under front main cover)

## WHEEL BEARING LUBRICATION, CLEAN & RE-PACK INSTRUCTIONS

**Grease wheel bearings as needed depending on amount of travel.**

Annually disassemble and clean parts in a solvent. Pack bearings with a high grade grease. Reassemble, and tighten nut until a slight drag is felt when wheel is turned. Back nut off and insert cotter pin into first hole that you see as you back the nut off, bend cotter pin over and re-install cap.

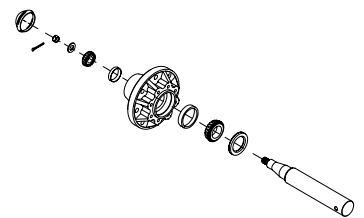

## LUBRICATION (cont.)



Telescoping PTO Drive (3 zerks)

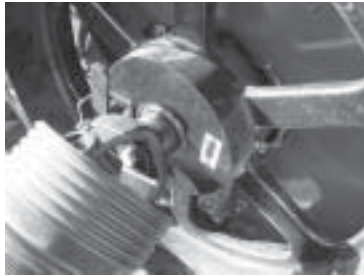

Flywheel (1 zerk)



Auger/Transmission Main Shear Bolt(1 zerk)



\*Front & Rear Mill Bearings  
(2 zerks - remote in Grease Bank under main shaft shield)  
\*Main Shaft Slider Bearings  
(2 zerks - remote in Grease Bank under main shaft shield)



Transfer Auger Front Bearing  
(under mill cover, 1 zerk on front bearing)



Transfer Auger Rear Bearings(2 remote zerks on rear of frame)  
Transmission Output Shaft Collar(1 remote zerk on rear of frame)  
Transmission Input Shaft Bearing(1 remote zerk on rear of frame)



Top of Mixing Auger  
(1 zerk - under top of tank cover)



Unloading Auger(1 zerk on the top of vertical section auger and 4 zerks on vertical auger pivot.)

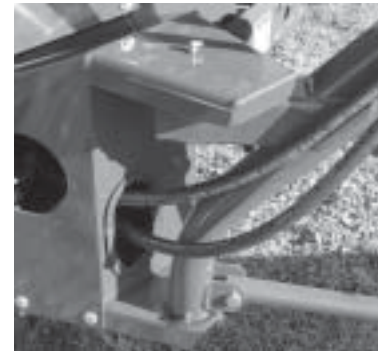

SIA Upper Pivot Bearing  
(1 zerk)  
SIA Lower Pivot Bearing  
(1 zerk)

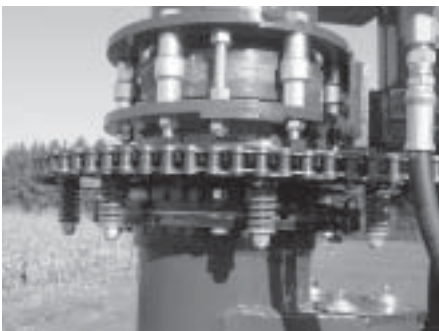

Unloading Auger Pivot/Collar  
(4 zerks - 2 on the top of the collar & 2 on the bottom of the collar)



Unloading Auger-(1 zerk at the end of the auger discharge spout)



Oil level should be between Max/Min level marks

# SERVICE

## HYDRAULIC SYSTEM

### Hydraulic Pump Sheave Alignment

The hydraulic pump drive and driven sheaves must be maintained in correct alignment and be tightly secured at all times.

### Hydraulic Pump Belt Tension

Overload protection for the hydraulic pump is provided by a self-adjusting spring tightener that requires no adjustment. The idler pulley must be properly positioned to keep the belt aligned with the sheaves.

### Cyclonic Hydraulic Reservoir

The oil filter should be replaced once a year or every 75 hours of operation, whichever comes first. The oil should be drained and replaced every two years or every 150 hours of operation, whichever comes first. Keep oil filled to proper level.

## MILL/BLOWER DRIVE

### Belt Replacement

To replace the mill/blower drive belt, perform the following steps:

1. Disengage PTO, shut-off tractor and remove key.
2. Release front drive chain tension.
3. Loosen both of the bolt/nut (A & B) assemblies on the main drive shaft.
5. After tension is released, remove the old belt and replace with a new belt.
6. Adjust the new belt tension per the Adjustment Chapter of this manual. After tension is properly adjusted, re-connect the front drive chain idler bracket spring.

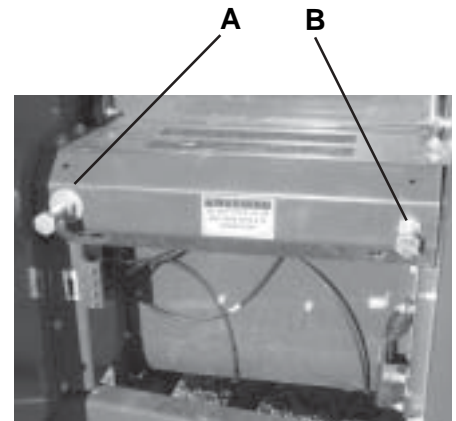

**IMPORTANT:** *The mill/blower drive belt will deteriorate more rapidly if improper tension is applied. Uneven sheave alignment will result in uneven belt stretch. Improper mill/blower belt tension will produce excessive pressure on the mill/blower bearings and cause premature bearing failure.*

# SERVICE

## MAIN DRIVE SHAFT BEARINGS

Main drive shaft bearings are greased by 2 of the remote zerks in grease bank under the step by the mill cover. For bearing replacement, follow steps 1-5 from the previous Belt Replacement section in this chapter. Then:

1. Disengage PTO, shut-off tractor and remove key.
2. Remove the hydraulic pump belt shield.
3. Release the spring tension on the hydraulic pump drive belt.
4. Remove the hydraulic drive pulley on the end of the main shaft.
5. Remove the drive chain to the transfer shaft.
6. Remove the PTO.
7. Remove the flywheel and flywheel clutch.
8. Remove the back left flywheel shield.
9. Remove remote grease lines from bearing blocks.
10. Remove main driveshaft cover with shaft and bearings.
11. Remove shaft and bearings from cover.
12. Loosen set screws and remove bearings.
13. Install new bearings and tighten set screws.
14. Re-install components in reverse order.
15. The bolt securing the PTO to the shaft should be tightened to seat the bearings. Then back the bolt out and tighten to 6-10 inch lbs. of torque. Secure the bolt with wire to PTO yoke.

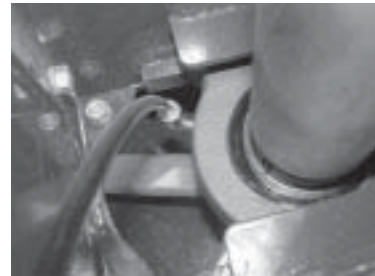

## ENGAGING PIN

The pin used to engage and disengage the mill/blower drive sheave should be checked periodically for excessive wear or improper seating. Excessive wear on the pin or the hole in the hub that the pin engages, could result in the pin accidentally disengaging in the middle of mill and blower operation. Both components should be replaced if worn.

**IMPORTANT:** Do not start the PTO until the pin is positively engaged. Using the PTO to engage the pin will cause premature pin failure.





# SERVICE

## MILL HAMMER ROTATION OR REPLACEMENT

To maintain maximum grinding efficiency, the mill hammers should be rotated before wear radius measures ¼" (6 mm). Mill hammers are designed to be conveniently removed and rotated through 4 positions, before they require replacement. The hammers should be replaced when all four corners are worn to ¼" (6 mm) radius.

The mill cylinder contains 3 rows with 22 hammers in each row. To remove a row of hammers, rotate the cylinder to the position where the row of hammers to be removed lines up with the access hole in the left side of the mill housing. With the access hole cover removed, pull the cotter pins out of the ends of the hammer rod and pull the rod out through the access hole.

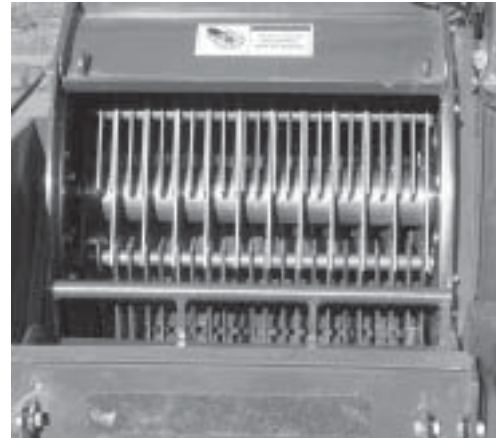

**NOTE:** Use a catch pan or install a small screen below the rod for the hammers and spacers to drop into as the rod is being pulled out.

**IMPORTANT:** Hammers and spacers must be replaced in proper sequence with respect to the appropriate row on the cylinder. When the hammers are rotated they should always be rotated in the same direction to maintain a balanced cylinder. All 3 rows of hammers should be rotated at the same time or replaced at the same time.

After the hammer rod is replaced and all of the hammers and spacers have been replaced, secure the rods in place with a new 3/16 x 1-1/4" cotter pins. Spread the points and bend them around the rod. Replace the access hole cover.

## MILL THROAT PLATE

The mill throat plate must be properly adjusted to hold the screen in place when the mill screen cover is closed and latched. Adjust the throat plate position with the 2 bolts on each side of the mill housing. To adjust the throat plate;

1. Disengage PTO, shut-off tractor and remove key.
2. Open the mill screen cover and install a screen into the screen support.
3. Loosen, but do not remove the 4 adjustment bolts and position the throat plate toward the bottoms of their mounting slots, then partially tighten the bolts.
4. Close the mill screen cover while forcing the screen against the throat plate.
5. Before latching the cover, tightly secure the 4 adjustment bolts to lock the throat plate position.

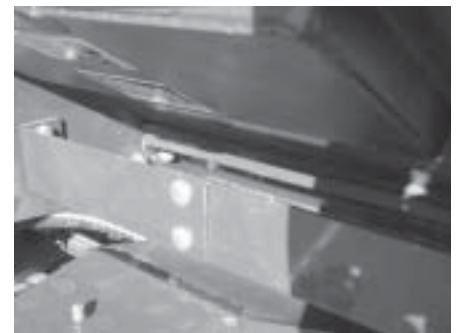

**NOTE:** The throat plate position should be adjusted regularly to maintain proper mill/screen operation and cover latching, and to prevent material from dropping out the bottom of the mill.

# SERVICE

## MIXING AUGER & TUBE

The mixing auger should be centered inside the tube at all times. Adjustment bolts are provided on the 4 supports which hold the tube for aligning and centering it around the auger. Access to the adjustment bolts and removing the mixing auger is gained through the tank lid opening in the top of the tank. The auger can be removed as follows:

1. Disengage the PTO, shut-off tractor and remove key.
2. Open the tank lid, loosen the bearing set collar and remove the bearing from the auger shaft.
3. Remove the top bearing bracket from the tank cover.
4. Remove the 2 paddles from the auger.
5. Remove the 4 supports from the tube.
6. Remove the tube and then the auger through the tank lid.

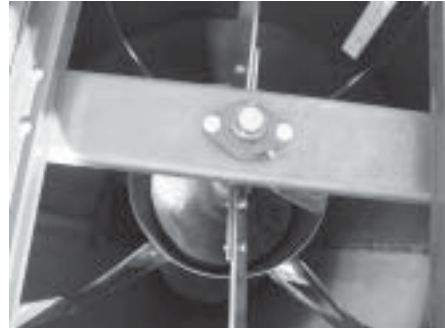

To replace the mixing auger or install a new auger, reverse the procedure of removal. After all components are replaced, the tube must be correctly centered around the auger and tightly secured.

## SHEAR BOLTS

### Main Shear Bolt

The main shear bolt located on the driven sprocket on the front end of the transmission drive shaft, protects the drive shaft, transmission and mixing auger. If the shear bolt fails, the transfer auger and mixing auger will also stop rotating. In case of an overload, the head of the bolt will shear off and stop shaft rotation. To replace the main shear bolt, proceed as follows:

**IMPORTANT:** Use only a 5/16 x 1" grade 5 shear bolt.

1. Disengage the PTO, shut-off tractor and remove key.
2. With the shifter pin engaged, rotate the mill/blower sheave by hand to align the keyhole in the sprocket with the slot in the shear flange. After proper alignment is obtained, disengage the shifter pin.
3. Turn the lock nut on the shear bolt flush and insert the bolt head through the keyhole and into the slot. Move the bolt down into the narrower portion of the keyhole.
4. Tighten the lock nut to fix the bolt position.
5. Grease the fitting on the sprocket to prevent the mechanism from seizing.

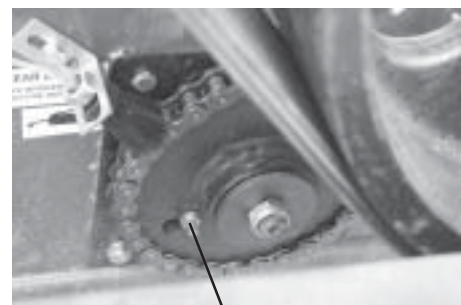

Main Shear Bolt

**IMPORTANT:** Remove the cause of the shear bolt failure before resuming operation. Grease the fitting on the sprocket any time a bolt is sheared.

# SERVICE

## Transfer Auger Shear Device

The transfer auger shear bolts are accessible only through the mill cover. This shear bolt protects the transfer auger flighting. If the shear bolts fail, the transfer auger will stop rotating even though the mixing auger and transmission drive shaft will continue to rotate.

**NOTE:** *Two 1/4" x 1-1/4" Grade 5 shear bolts are used on the shear hub.*

To replace the shear bolts, proceed as follows:

1. Disengage the PTO, shut-off tractor and remove key.
2. For access to the shear bolt, open mill cover door and remove the material in the bottom of the transfer auger.
3. Remove any shear bolt parts remaining in the shear hub.
4. Line up the shear bolt holes by manually rotating the flywheel.
5. Replace both shear bolts using the *1/4" x 1-1/4" Grade 5* shear bolts stored on the inside of the front cover.
6. After the cause of the shear bolt failure is corrected and the bolts have been replaced, place the mill/blower engaging pin in the engaged position and rotate the flywheel by hand checking the intake auger for rotation before attempting to resume grinding.
7. Close the mill cover door and resume operation.

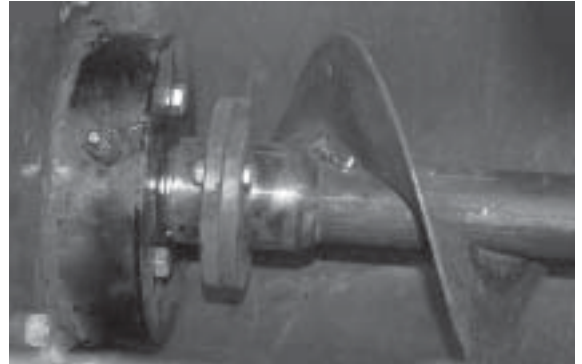

**IMPORTANT:** *When restarting the grinder mixer, place the tractor throttle at idle before engaging the PTO.*

# SERVICE

## TRANSMISSION

The GM 170 transmission can be removed from the mixer for taking it to the dealer for internal component service.

*Note: Internal component repairs and replacement should only be attempted by (or under the direction of) an authorized H&S Manufacturing Dealer.*

To remove the transmission from the mixer;

1. Disengage the PTO, shut-off tractor and remove key.
2. Release the drive chain tension and uncouple the chain.
3. Remove the remote grease fitting from the input auger bearing.
4. Remove the bolts securing the gearbox shaft brace.
5. Remove the cap screws that secure the transmission to frame.
6. Repair transmission.
7. Replace the transmission in reverse order of removal.
8. Adjust drive chain tension following details in the Adjustments Chapter.



**NOTE:** Check the transmission oil level periodically.

## UNLOADING AUGER

If the Unloading Auger System becomes plugged, proceed as follows:

1. Disengage the PTO, shut-off tractor and remove key.
2. Shut the unload auger door and turn off the variable speed control valve.
3. Remove the cleanout covers on the lower and vertical unloading augers and remove as much material as possible.
4. Replace the lower and vertical unloading auger cleanout covers
5. Hydraulically lower the main discharge auger to the lowest position.
6. Re-start the tractor, engage the PTO, and slowly engage the variable speed control valve to clear the remaining material from the discharge augers.

**NOTE:** If the plugging is due to an improperly attached extension, check and correct before attempting to resume unloading.



Lower Unloading Auger Cleanout

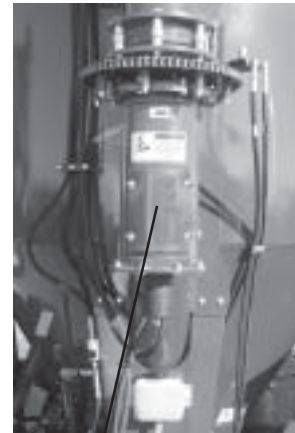

Vertical Unloading Auger Cleanout

## TIRES & WHEELS

Check the Tire pressure after every 50 hours of operation. Tires should be inflated to 80 PSI (563kpa). Wheel lugs torque should also be checked after every 50 hours of operation and tightened to 90 ft-lb (124 Nm) torque.



# **OPTIONAL FEATURES & ACCESSORIES**

## **ELECTRONIC SCALES & COMPONENTS**

### **Model: Digi-Star EZ 2000**

An optional factory installed Digi-Star EZ 2000 scale is available for accurate weight measurement. The 3-point Weighbar System features 3 modes, Net, Tare and Gross.



### **Model: Digi-Star EZ 3200 w/External Horn**

An optional factory installed Digi-Star EZ 3200 scale is available with all the features of the EZ 2000, plus an external horn, and has the capability for entering rations.

## **SWINGING INTAKE AUGER (SIA)**

An optional Swinging Intake Auger(SIA) with a variable speed control is available for the GM 170.



## **FENDER SET**

A fender set is available and consists of 2 fenders, 4 fender support angles and attaching hardware. Installation instructions are packaged with the kit of parts.



## **TRANSPORT LIGHTING**

An optional highway transport lighting kit is available.



## **SCREENS**

12 sizes of screens are available. Sizes include:  
1/8", 3/16", 1/4", 5/16", 3/8", 1/2", 5/8", 3/4", 1", 1-1/4", 1-1/2", & 2".



# OPTIONAL FEATURES & ACCESSORIES

## UNLOADING AUGER EXTENSIONS

### 3' Folding Auger Extension

The 3' folding discharge auger extension kit consists of a 3' length of auger which is attached on a pivoting mounting bracket to the end of the 12' unloading auger.

**NOTE: The 3' folding auger extension must be folded back and locked in position for transport.**



### 6' Folding Auger Extension

The 6' folding discharge auger extension kit consists of a 6' length of auger which is attached on a pivoting mounting bracket to the end of the 12' unloading auger.

**NOTE: The 6' folding auger extension must be folded back and locked in position for transport.**



# TROUBLESHOOTING

**NOTE:** *This Troubleshooting Chapter presents problems, causes and suggested remedies beyond the extent of loose, worn or missing parts and it was developed with the understanding that the machine is in otherwise good operating condition.*

## MILL & MIXER DRIVE

PROBLEM	CAUSE	REMEDY
PTO Shaft vibrates excessively.	Improper tractor hook-up	Adjust hook-up.
	Tractor being operated at an angle.	Align tractor straight-away with Grinder-Mixer.
	PTO shaft bent.	Replace PTO shaft.
	PTO shaft bearings worn.	Replace bearings
Mill/Blower doesn't turn.	Mill Engaging Pin not engaged or improperly engaged.	Engage Pin.
	Mill/Blower drive belt slipping.	Adjust belt tension.
Mixing Auger doesn't turn.	Transmission shear bolt sheared.	Replace bolt and correct cause of bolt failure.
	Front drive chain disconnected.	Repair or replace chain.
	Transmission rear drive chain disconnected.	Repair or replace chain.
	Sprocket key sheared.	Replace key.
	Transmission gear key sheared.	Replace key.
	Broken shaft.	Replace shaft.
Transfer Auger doesn't turn.	Transfer auger shear bolt sheared.	Replace bolt and correct cause of bolt failure.
	Front drive chain is broken or disconnected.	Repair or replace chain.

# TROUBLESHOOTING

## MILL

PROBLEM	CAUSE	REMEDY
Decreased or low capacity	<p>Mill not operating at the recommended RPM speed.</p> <p>Mill loses speed as material enters it.</p> <p>Screen worn.</p> <p>Blower inlet plugged.</p>	<p>Adjust tractor throttle to proper RPM speed.</p> <p>Adjust Mill/Blower sheave alignment and/or drive belt tension.</p> <p>Rotate or replace screen.</p> <p>Unplug.</p>
Excess vibration.	<p>Uneven flow of grain into the mill.</p> <p>Excess RPM.</p> <p>Mill bearings worn or defective.</p> <p>Flywheel bearings worn or improperly adjusted.</p> <p>Hammers missing or broken.</p> <p>Blower unbalanced.</p>	<p>Transfer grain into the mill as smoothly as possible.</p> <p>Operate at 540 RPM.</p> <p>Replace bearings.</p> <p>Replace and/or properly adjust bearings.</p> <p>Replace hammers.</p> <p>Remove, balance &amp; replace.</p>
Excessive dust.	<p>Blower inlet plugged.</p> <p>Collector covered.</p>	<p>Check &amp; unplug.</p> <p>Uncover collector while operating.</p>
Material not ground to desired size.	<p>Incorrect screen being used.</p> <p>Mill speed too high or low.</p>	<p>Change screen diameter to correct size.</p> <p>Adjust to correct RPM speed.</p>
Material will not flow through mill hopper.	<p>Mixer is sloped towards the feeding side.</p> <p>Material too damp.</p> <p>Material too light or bulky.</p>	<p>Reposition mixer on level ground.</p> <p>Adjust slope of intake hopper.</p> <p>Adjust slope of intake hopper.</p>

## UNLOADING

PROBLEM	CAUSE	REMEDY
Tank won't unload or stops unloading.	Bridging in tank.	Shut-off mixer and tractor, break up bridging by probing through the access doors.
Tank unloads too slow.	Discharge slide is not open all the way.	Open slide up more.

# TROUBLESHOOTING

## HYDRAULICS

**Note:** In troubleshooting a self-contained hydraulic system, it is necessary to isolate the pump from the hydraulic motors to determine which unit is malfunctioning. A worn pump or motor will both give the same system indication. Run a pressure and flow check on the pump first to make sure that it is performing within the operating specifications, then check the motor for the correct specifications. Oil flow must be checked at the rated PTO speed. Flow should be 9.2 GPM at 1000 PSI.

PROBLEM	CAUSE	REMEDY
Discharge augers do not turn.	Variable speed flow control valve in off position. Pump defective. Hydraulic motor defective. Hydraulic pressure too low. Foreign object lodged in auger.	Turn variable speed flow control valve on. Replace pump. Replace or repair hydraulic motor. Check for restriction in hydraulic lines. Remove foreign object.
Difficult to engage or disengage variable speed control valve.	Variable speed control valve defective.	Replace variable speed control valve.
Pump will not turn.	Belt out of grooves. Belt does not have proper tension. Pump defective. Return line blocked or restricted.	Realign sheaves and adjust belt tension. Replace idler tension spring or properly position idler. Check oil flow and replace pump if necessary. Remove blockage and replace oil and filter if dirty.
Pump squeals during start up.	Oil too heavy/cold. Oil level in reservoir too low.	Allow oil to warm up or switch to a recommended lighter oil. Add oil to bring between min/max indicator levels.
Augers operating slow.	Improper oil flow. Plugged oil filter. Hydraulic pump defective. Variable speed control valve not open all the way. Hydraulic motor defective. Oil too thin. Not enough oil flow to hydraulic pump.	Check pump output pressure as applicable. Replace filter. Replace hydraulic pump. Open variable speed control valve more. Repair or replace hydraulic motor. Replace with heavier oil. Change oil filter, replace oil with new oil and fill to proper level.



# TROUBLESHOOTING

## HYDRAULICS

PROBLEM	CAUSE	REMEDY
Tank unloads slow.	Insufficient oil flow to motors. Plugged oil filter. Hydraulic pump defective. Variable speed control valve not open all the way. Hydraulic motor defective. Oil too thin. Not enough oil flow to hydraulic pump. Loose connection to the motor.	Increase tractor RPM speed. Replace filter. Replace hydraulic pump. Open variable speed control valve more. Repair or replace hydraulic motor. Replace with heavier oil. Change oil filter, replace oil with new oil and fill to proper level. Check and tighten connection.
None of the motors operate.	Pump not being driven. Hydraulic pump defective. Discharge auger variable speed control valve relief pressure set too low.	Check sheaves and belt for malfunction. Replace hydraulic pump. Check pressure to valve, if pressure is low adjust to factory setting or replace if it will not adjust.
Discharge auger variable speed control valve will not engage or disengage.	Variable speed control valve defective.	Replace variable speed control valve.
Swinging Intake Auger (SIA) attachment will not operate.	SIA variable speed control in the off position. SIA variable speed control valve relief pressure set too low.	Check mechanical linkage controls and open valve. Check pressure to valve, if pressure is low adjust to factory setting or replace if will not adjust.
Auger in SIA turns in the wrong direction.	Motor connections crossed.	Switch hose connections to change direction of motor rotation.

# **TROUBLESHOOTING**

## **HYDRAULICS**

<b>PROBLEM</b>	<b>CAUSE</b>	<b>REMEDY</b>
SIA turns too slow.	Excessive or wet grain.  Not enough oil flow to hydraulic pump. Hydraulic pump defective. Hydraulic motor defective. SIA relief valve pressure set too low.  SIA auger partially plugged.  SIA pressure relief valve doesn't function properly.	The higher the moisture content and weight of the material that is being conveyed, the more power it takes. Adjust the variable speed control valve to allow more oil to the hydraulic motor.  Change oil filter, replace oil with new oil and fill to proper level.  Replace hydraulic pump.  Repair or replace hydraulic motor.  Check pressure to valve, if pressure is low adjust to factory setting or replace if will not adjust.  Remove plugging material.  Check pressure to valve, if it will not adjust to the factory setting, replace the valve.

## DECAL PLACEMENT

Your H&S 170 Grinder-Mixer was manufactured with operator safety in mind. Located on GM 170 are various decals to aid in operation, and to warn of danger or caution areas. Pay close attention to all the decals on your Grinder-Mixer.



**DO NOT REMOVE ANY OF THESE DECALS. IF DECALS ARE LOST, DAMAGED, OR IF YOUR GRINDER-MIXER IS REPAINTED, REPLACE DECALS. REMEMBER: DECALS ARE FOR YOUR PROTECTION AND SAFETY.**

Listed below are the decals on your 170 Grinder-Mixer. These decals may be ordered individually by part number, or by ordering as a complete set.

<u>Part Number</u>	<u>Description</u>
112-11176	Shear Bolts - Remove broken shear bolt before replacing
120-2177	Pull to Stop
1494A	Do not operate this equipment if this decal is exposed. Replace safety shields
1494J	Do not clean or work on this machine without first disengaging power
1494K	Do not remove shields - moving parts inside
1494L	Rotating driveline
093466	Operate only with 540 RPM PTO
1494P	Maintain safe clearance from electrical power lines
2595	Keep children away at all times
9194A	No step - stay clear
11599	Do not go near leaks
32597A	Do not operate this equipment if this decal is exposed. Replace safety shields
72203A	Help avoid injury - Read and understand the operators manual
82407	H&S GM 170
82602	Crushing Hazard
82907A	Stay clear of discharge auger
82907B	Stay clear of auger extension hinge area
82907C	Stay clear - Keep hands and feet away from auger at all times
82907D	Stay clear - Rotating parts inside
82907E	Stay clear - Rotating auger behind this panel
82907F	Keep out - Do not enter tank - Keep cover closed
82907G	Stay clear - Keep hands out of supplement hopper
82907H	Stay clear - Keep hands and feet away from auger at all times
82907I	Do not step up on machine while in operation
82907J	Operator's manual is located behind this shield
093366	Keep Operator's Manual Here
82907K	Cyclone cover - Open/Close
82907L	Never allow riders on this machine
82907M	Discharge auger door - Open/Close
093020	Grease zerk decal
B12	H&S decal
GM-A	95 -135 bushel decal
GM-B	55 - 85 bushel decal
5696D	Disengage
5696E	Engage
ZX21	Red paint - Gallon
ZX22	Red paint - Quart
ZX23	Red paint - Pint
ZX79	Red paint - Spray Can
	Red Reflector
	Amber Reflector

# DECAL PLACEMENT

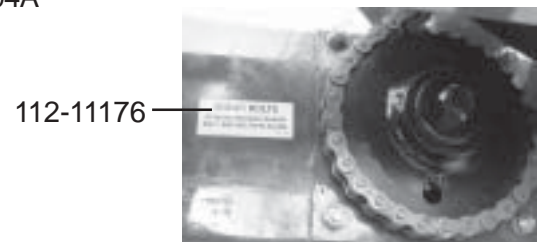
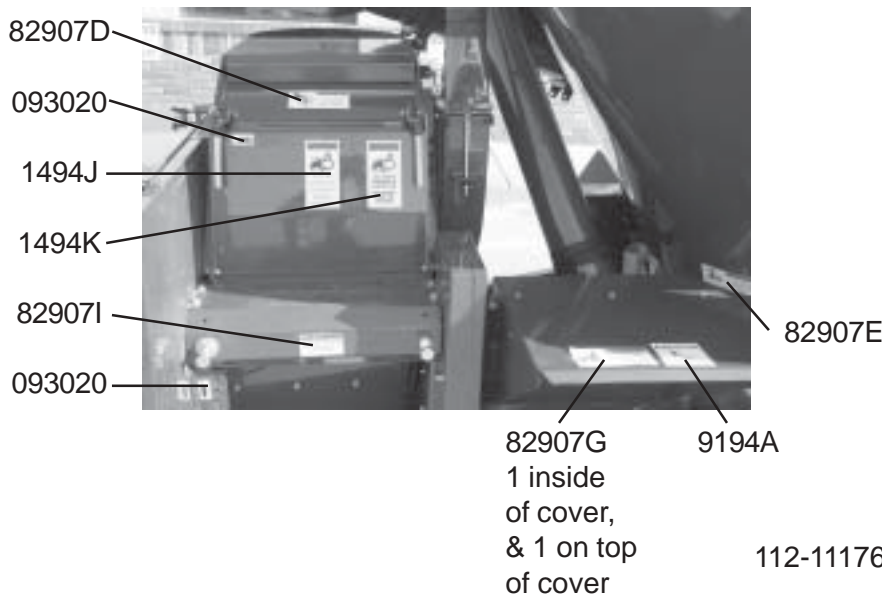
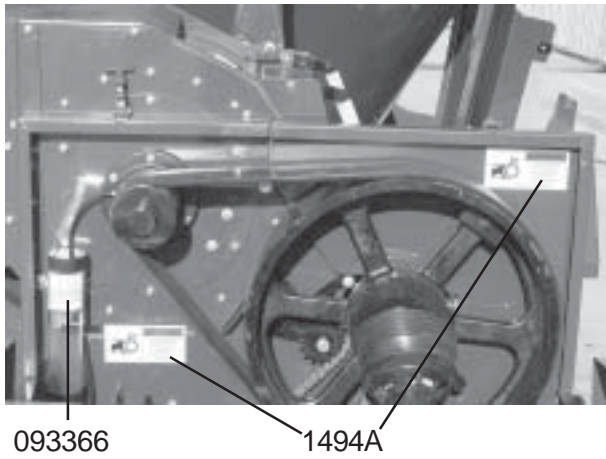
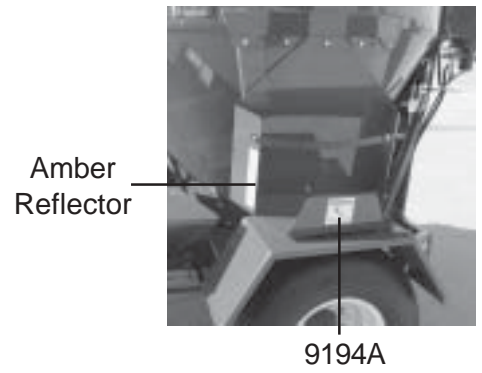
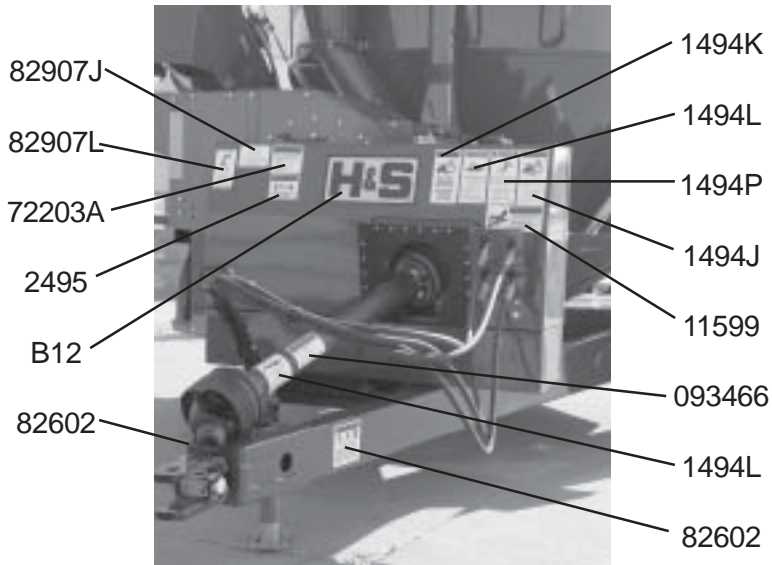

# DECAL PLACEMENT

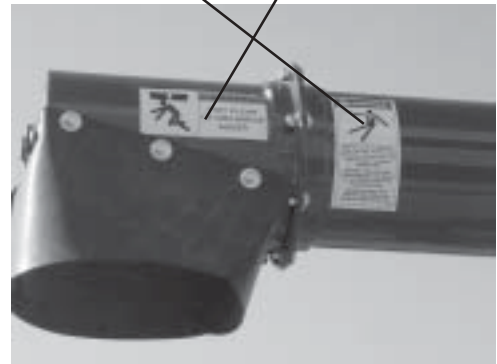
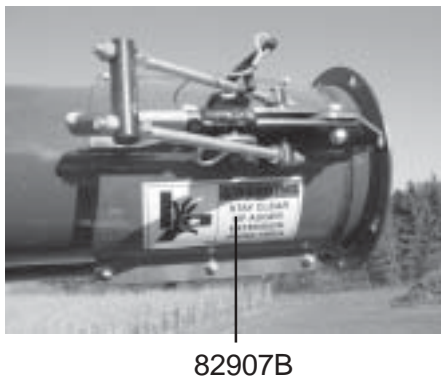
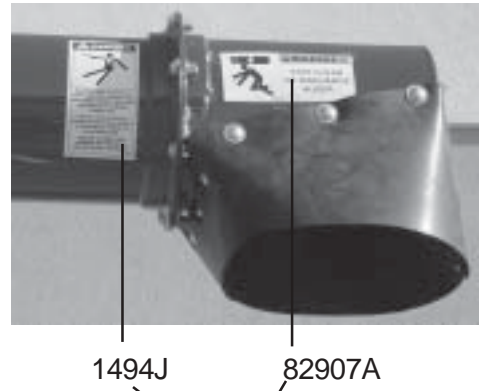
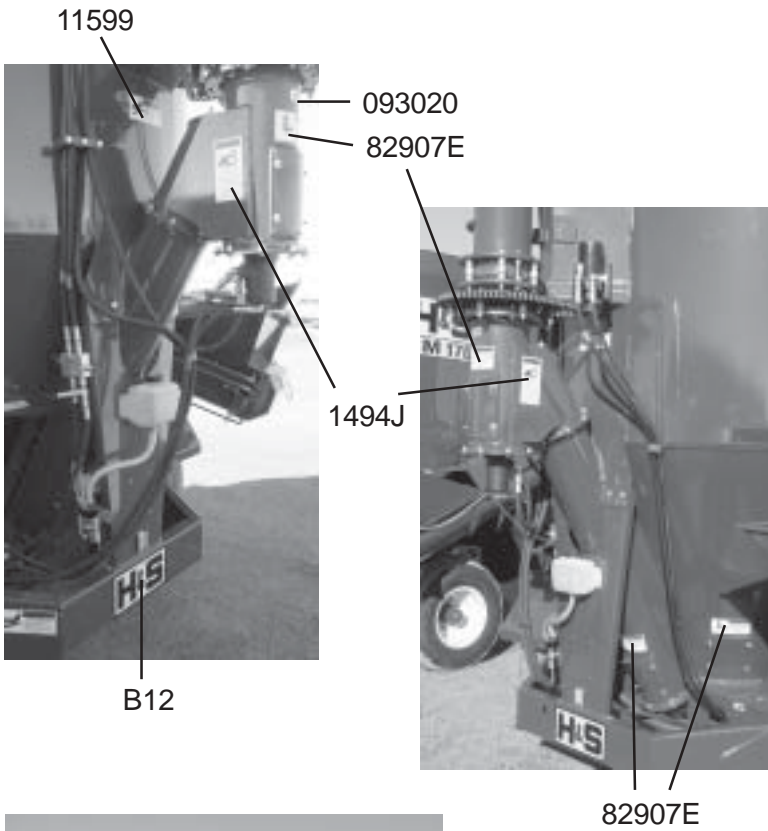
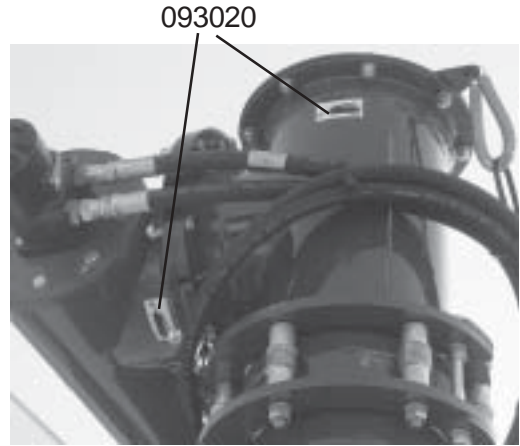
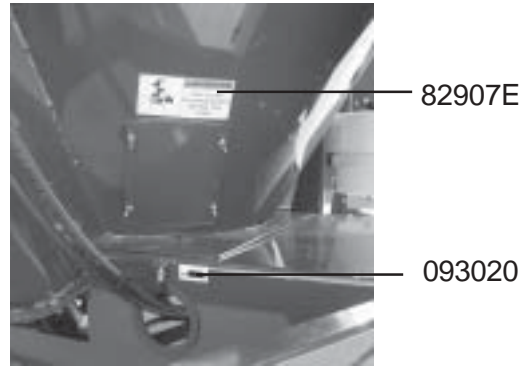
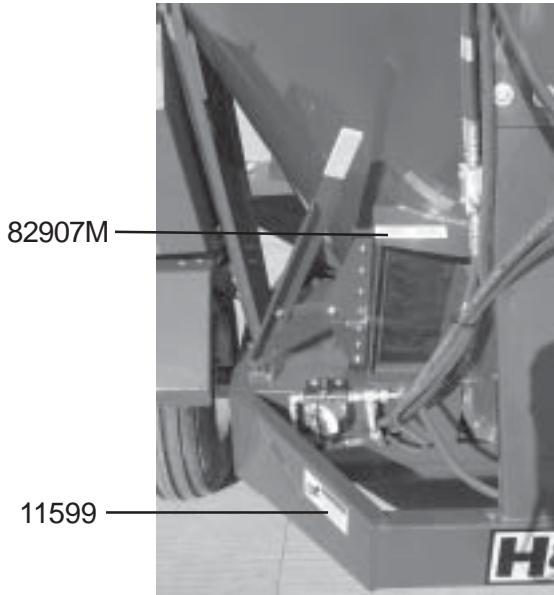



# DECAL PLACEMENT

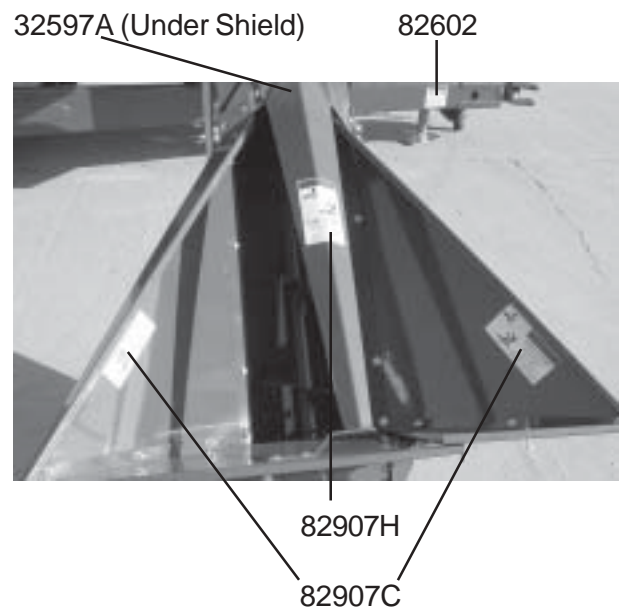
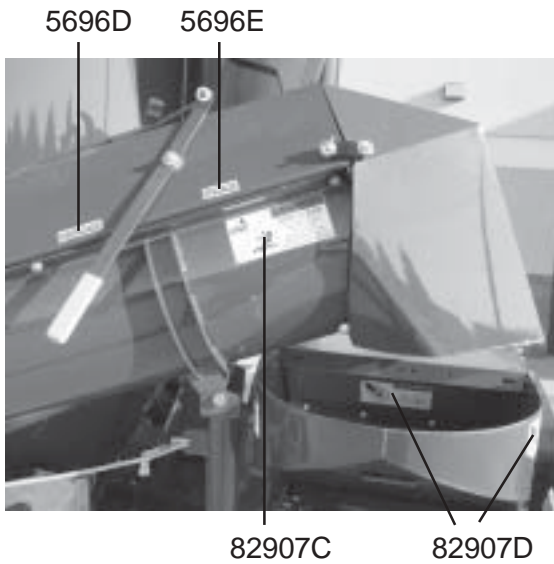
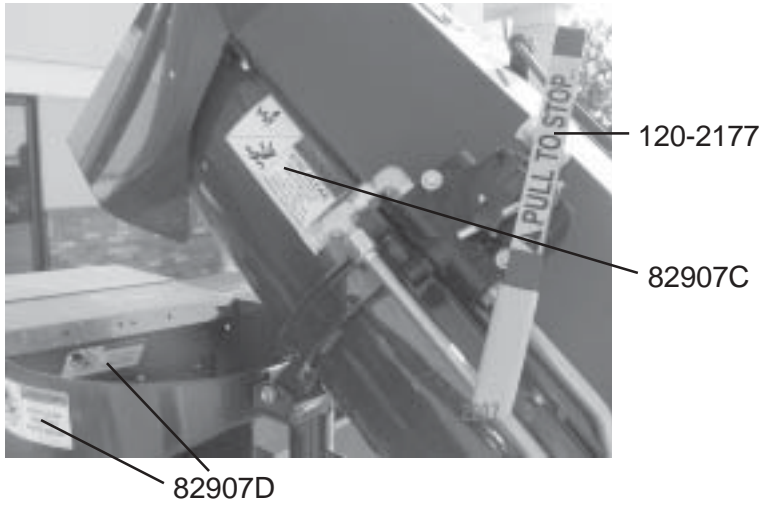
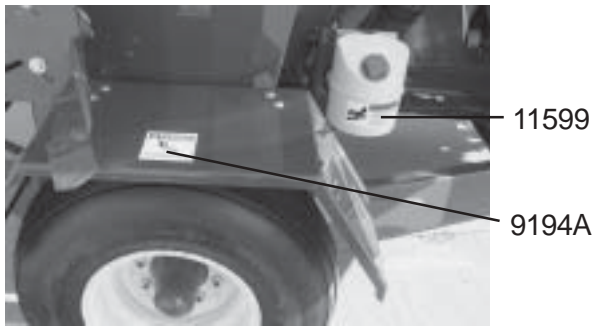

# INSTRUCTIONS FOR ORDERING PARTS

All service parts should be ordered through your authorized H & S dealer. They will be able to give you faster service if you will provide them with the following

1. Model & Serial number is located on the main frame.
2. All reference to left or right apply to the machine as viewed from the rear.
3. Parts should not be ordered from illustration only. Please order by complete part number.
4. If your dealer has to order parts - give shipping instructions:

VIA truck - large pieces (please specify local truck lines)

VIA United Parcel Service (include full address)

H&S MFG. CO. INC.	
MARSHFIELD, WIS.	
MOD. NO.	<input type="text"/>
SER. NO.	<input type="text"/>
DESCR.	<input type="text"/>

PLEASE RECORD NUMBERS FOR YOUR UNIT FOR QUICK REFERENCE

## **ABOUT IMPROVEMENTS**

**H&S IS CONTINUALLY STRIVING TO IMPROVE IT'S PRODUCTS**

We must therefore, reserve the right to make improvements or changes whenever it becomes practical to do so without incurring any obligation to make changes or additions to the equipment previously sold.



# Figure 1 Frame

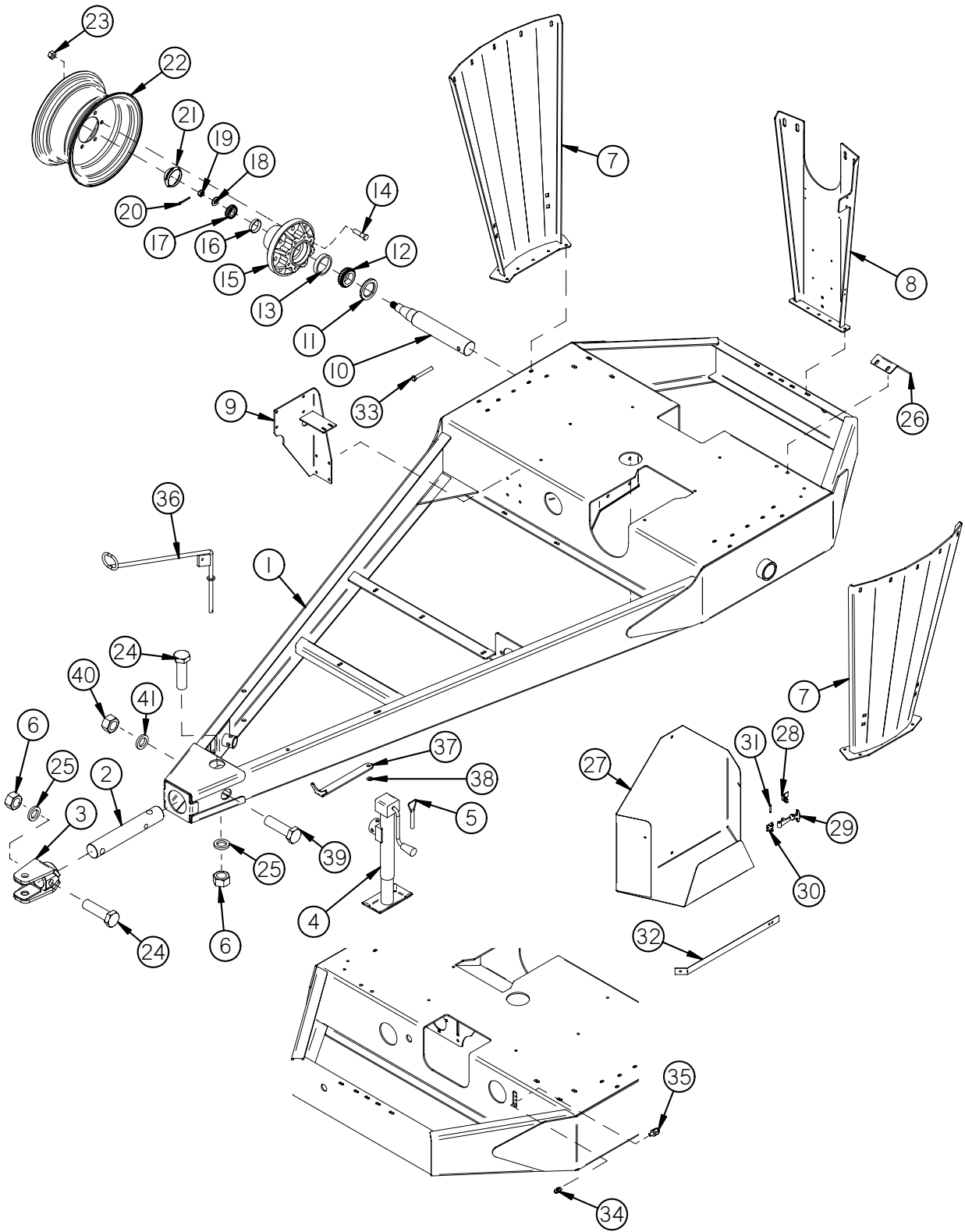

# Figure 1 Frame

ITEM #	PART #	DESC.
1	GM72	Frame
2	GM73	Hitch Shaft
3	GM74	Hitch
4	GM396	Jack
5	12N13	Jack Pin & Chain
6	T151	1" Nut
7	GM76	Tank Side Support
8	GM77	Tank Back Support
*	F97	SMV Bracket
9	GM78	Oil Tank Bracket
10	GM79	Spindle
11	B90	Seal
12	B91	Inner Bearing
13	B91A	Inner Race
14	26G5A	Stud 5/8"-18
15	26G4A	Hub (821)
16	B94A	Outer Race
17	B94	Outer Bearing
18	B4	Washer
19	B3	Nut
20	B31	Cotter Pin
21	B2	Hub Cap
22	RG73	Wheel (W-51350)
*	GM394	Tire (12.5L x 15 20 Ply)
23	26G6A	Lug Nut 5/8"-18
24	GM80	1" x 5" GR 5 Bolt
25	DWM171	1" Lock Washer
26	GM397	Flow Control Bracket
27	GM398	Screen Holder
28	X193	Latch Keeper
29	X192	Rubber Latch
30	X194	Latch Mounting Bracket
31	X195	Latch Pin
32	GM399	Screen Holder Strap
33	B10	1/2" x 4" GR. 5 Bolt
34	G89	Grease Zerk (#1641)
35	GM424	1/4"-28 Grease Line Adapter
36	GM440	Grinder Hose Holder
37	42N2	PTO Holder
38	42N3	Spring (MB1000-035)
39	GM183	3/4" X 4-1/2" GR 5 Bolt
40	GM417	3/4"-10 Nut
41	RG199	3/4" Lock Washer

\* Means Not Shown



**Figure 2**  
**Tank**

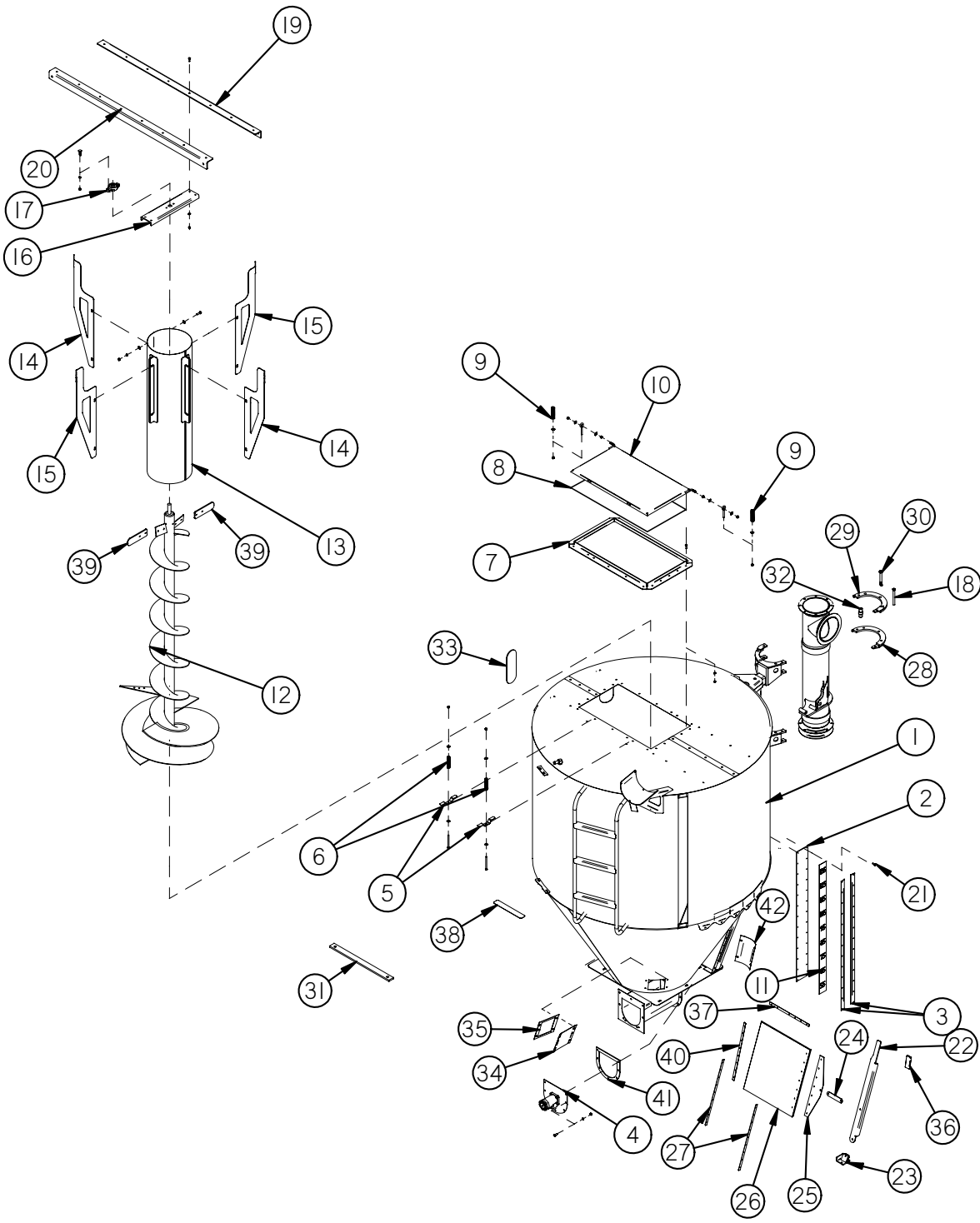

## Figure 2 Tank

ITEM #	PART #	DESC.
1	GM301	Tank
2	GM302	Window
3	GM303	Window Frame
4	GM304	Motor Mount
5	GM305	Lid Latch
6	GM225	Latch Spring (A262)
7	GM307	Lid Frame
8	GM308	Lid Gasket
9	GM309	I Bolt & Spring Assy. (A162 Spring)
10	GM310	Lid
11	GM-A & GM-B	Decal (Bushel Scale - upper and lower)
12	GM311	Mixing Auger
13	GM312	Mixing Auger Tube
14	GM313	Mixing Tube Support B
15	GM314	Mixing Tube Support
16	GM315	Mixing Auger Top Support
17	T40	Bearing
18	GM463	1/2" x 5" GR.5 Bolt Full Thread
19	GM317	Tank Top Frame Channel Back
20	GM318	Tank Top Frame Channel Front
21	GM234	Pop Rivet 3/16" x .700" (0155997)
22	GM334	Door Handle
23	GM335	Door Stop
24	GM336	Door Linkage
25	GM337	Door Edge
26	GM338	Door
27	GM339	Door Seal Strap
*	GM348	Rubber Door Seal Front (Left)
*	GM349	Rubber Door Seal Back (Right)
28	GM340	Split Ring Bottom
29	GM341	Split Ring Top
30	GM342	Step Bolt
31	GM442	Poly Strip
32	GM345	Roller
33	GM346	Top Sight Window
*	GM347	Window Gasket
34	GM356	Cleanout Door
35	GM357	Cleanout Gasket
36	S403	Handle Grip
37	GM391	Inside Door Seal Strap
*	GM392	Inside Door Seal
38	GM435	Safety Tread
39	GM437	Paddle Mixer
40	GM438	Door Seal Strap
*	GM439	Rubber Door Seal
41	GM320	Auger Bottom Cap Spacer
42	GM488**	Auger Cleanout Cover
*	GM509**	Felt Gasket

\* Means Not Shown

\*\* Means Used on Serial #900104 and Higher

# Figure 3 Concentrate Hopper & Collector

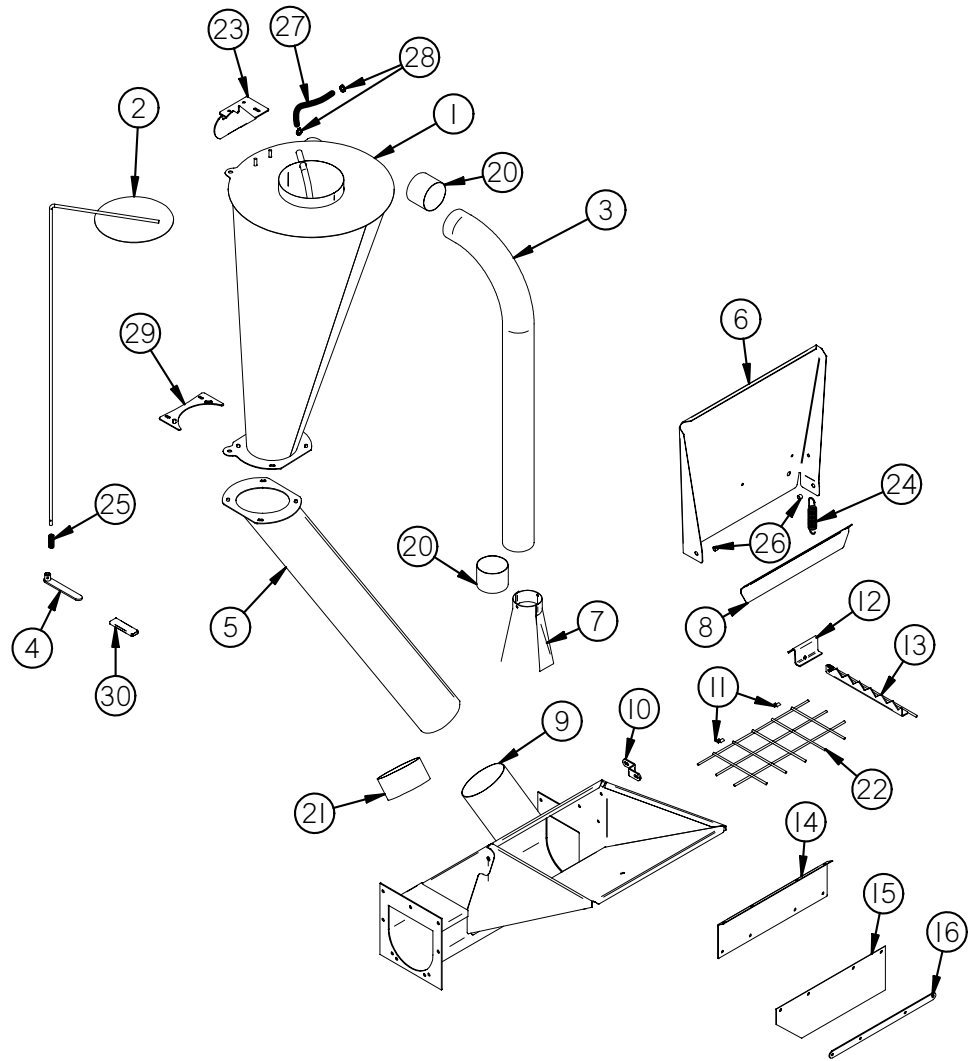

## Figure 3 Concentrate Hopper & Collector

ITEM #	PART #	DESC.
1	GM81	Dust Collector
2	GM82	Dust Collector Cover
3	GM83	Blower Pipe
4	GM84	Cover Handle
5	GM85	Dust Collector Pipe
6	GM86	Cover Hopper
*	GM420	Cover Seal
7	GM87	Blower Transition Chute
8	GM88	Stop Cover
9	GM89	Supplement Hopper
10	GM90	Retainer Guard
11	GM91	Hose Clamp
12	GM92	Support Breaker
13	GM93	Breaker Bar
14	GM94	Dust Shield
15	GM95	Dust Flap
16	GM96	Dust Flap Retainer
20	GM100	Blower Pipe Seal
21	GM101	Dust Collector Seal
22	GM360	Hopper Grate
23	GM368	Adjustable Mount Plate
24	K103	Spring (SP10)
25	17G128	Spring
26	GM443	Supplement Hopper Door Pivot
27	GM452	3/4" x 14" Hose
28	GM453	1" Hose Clamp
29	GM460	Adjustable Support Bottom
30	GM370	Handle Grip

\* Means Not Shown

# Figure 4 DriveLine

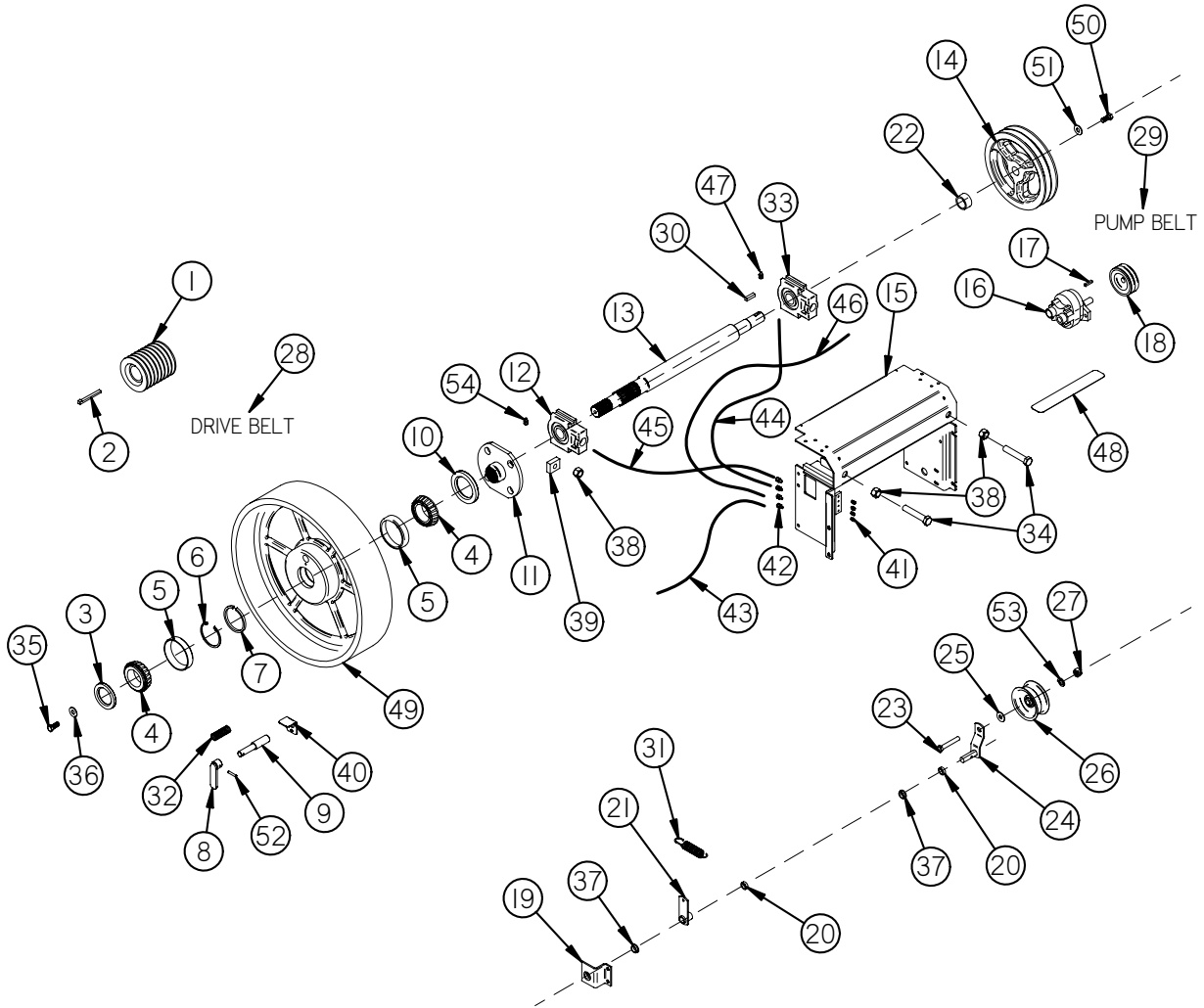



## Figure 4 DriveLine

ITEM #	PART #	DESC.	ITEM #	PART #	DESC.
1	GM102	Mill Sheave 540 RPM	45	GM427	Grease Line 20"
*	GM103	Mill Sheave 1000 RPM	46	GM428	Grease Line 85"
2	GM104	Key 3/8" Taper	47	GM429	1/4"-28 90° Adapter
3	GM105	Seal (22338)	48	GM435	Safety Tread
4	GM106	Outer Bearing (LM501349)	49	GM41	Flywheel
5	GM107	Race (LM501310)	50	GM456	1/2"-20 x 1-1/4" GR 5 Bolt
6	GM108	Snap Ring	51	GM124	540 Sheave Washer
7	GM109	Spacer	52	GM40	1/4" x 1-1/4" Expansion Pin
8	GM110	Clutch Handle	53	T69	5/8" Lock Washer
9	GM111	Clutch Pin	54	GM419	1/8" Grease Line Adapter
10	GM112	Seal (22430)			
11	GM113	Flywheel Clutch			
12	GM114	Bearing (UCT- 210-31 11/16)			
13	GM115	Main Drive Shaft			
14	GM508	Pump Drive Sheave (540 RPM) 2AK124			
*	GM117	Pump Drive Sheave (1000 RPM) 2AK74			
15	GM118	Drive Shaft Carrier			
16	GM14	Pump			
17	GM275	Key 3/16" x 1" (Square Key Round Ends)			
18	GM120	Pump Sheave			
19	GM121	Idler Shaft Support			
20	GM122	Spacer			
21	GM123	Arm			
22	GM444	Sheave Spacer (540 & 1000 RPM)			
23	BFR438	Bolt 5/8" x 2"			
24	GM125	Idler Arm			
25	RG8	5/8" Flat Washer			
26	GM127	Idler Pulley			
27	GM128	5/8"-11 Nut			
28	GM129	V Belt (8/A91) (540 RPM) 93"			
*	GM130	V Belt (8/A96) (1000 RPM) 98"			
29	GM131	V Belt (2/A62) (540 RPM) 64"			
*	GM132	V Belt (2/A52) (1000 RPM) 54"			
30	G12	Key 5/16" x 1" (540 & 1000 RPM)			
31	GM410	Spring (B11108) 540 RPM			
*	GM454	Spring (U10063) 1000 RPM			
32	GM411	Spring (13E29)			
33	GM413	Bearing (UCT208-24-11/16)			
34	GM306	Bolt 3/4" x 5" GR. 5 Full Thread			
35	GM414	1/2"-20 x 1-1/4" GR. 5 Bolt w/Hole			
36	GM415	Input Yoke Washer			
37	GM416	Idler Pivot Bushing			
38	GM417	3/4"-10 Nut			
39	GM445	Slider Bearing Nut			
40	GM423	Flywheel Clutch Bracket			
41	G89	Grease Zerk (#1641)			
42	GM424	1/4"-28 Grease Line Adapter			
43	GM425	Grease Line 70"			
44	GM426	Grease Line 25"			

\* Means Not Shown

# Figure 5 Mill

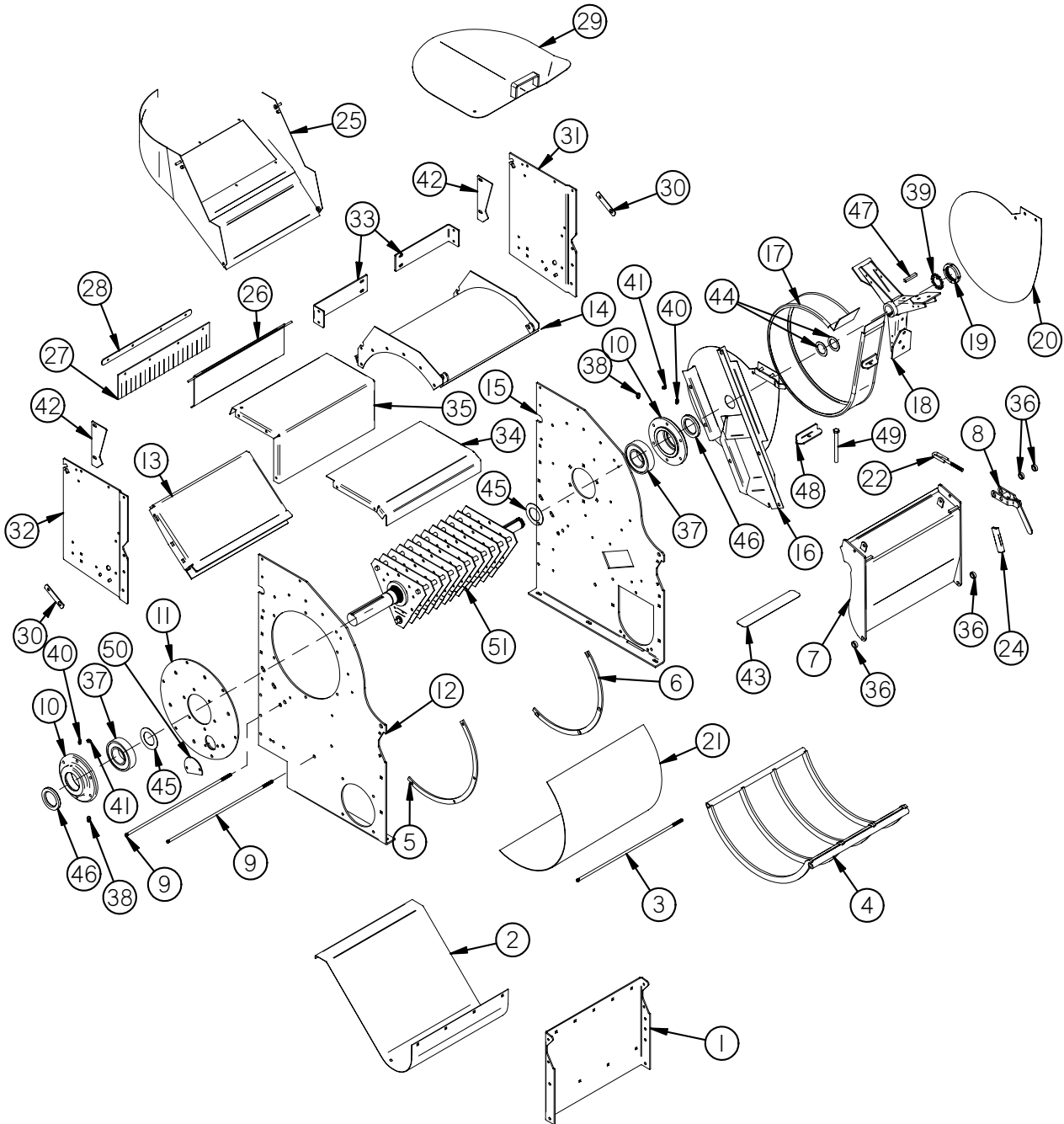

## Figure 5 Mill

ITEM #	PART #	DESC.	ITEM #	PART #	DESC.
1	GM133	Grinder Side Panel	37	GM421	Bearing (J211WDN)
2	GM134	Mill Bottom Panel	38	GM419	1/8" Grease Line Adapter (244054)
3	GM135	Mill Long Bolt 1/2" x 22.500"	39	GM431	Locking Washer (WH-08)
4	GM136	Screen Support	40	GM432	3/8"-16 Set Screw w/Point
5	GM137	Screen Guide Front	41	S355	3/8"-16 Jam Nut
6	GM138	Screen Guide Back	42	GM433	Chute Stop
7	GM139	Grinder Door	43	GM435	Safety Tread
8	GM140	Door Latch	44	GM448	Fan Spacer
9	GM141	Rod 3/8" x 22.375"	45	GM449	Bearing Spacer
10	GM142	Bearing Housing	46	GM450	Seal (2608)
11	GM143	Cylinder Cover	47	GM462	3/8" x 2-1/2" Key
12	GM144	Mill Front Panel	48	GM316	Blower Band Angle
13	GM145	Throat Plate	49	GM323	3/8" x 8-1/2" GR 5 Bolt
14	GM146	Grinder Top	50	GM457	Service Port Cover
15	GM147	Mill Back Panel	51	GM451	Complete Mill Cylinder
16	GM148	Front Blower Panel			
17	GM149	Blower Band			
18	GM150	Blower Fan			
19	GM151	Nut (N-08)			
20	GM152	Blower Back Panel			
21	GM154	Hammer Mill Screen 1/8"			
*	GM155	Hammer Mill Screen 3/16"			
*	GM156	Hammer Mill Screen 1/4"			
*	GM157	Hammer Mill Screen 5/16"			
*	GM158	Hammer Mill Screen 3/8"			
*	GM159	Hammer Mill Screen 1/2"			
*	GM160	Hammer Mill Screen 5/8"			
*	GM161	Hammer Mill Screen 3/4"			
*	GM162	Hammer Mill Screen 1"			
*	GM163	Hammer Mill Screen 1-1/4"			
*	GM164	Hammer Mill Screen 1-1/2"			
*	GM165	Hammer Mill Screen 2"			
22	GM166	Door Hook			
24	GM370	Handle Grip			
25	GM351	Infeed Chute For Infeed Conveyor			
*	GM352	Chute Magnet			
26	GM353	Infeed Flap			
27	GM354	Infeed Flap Rubber			
28	GM355	Infeed Flap Rubber Strap			
29	GM358	Infeed Chute Cover for Item # 25			
30	GM362	Hopper Adjustment			
31	GM363	Grinder Throat Left			
32	GM364	Grinder Throat Right			
33	GM365	Chute Brace			
34	GM366	Chute Mid Shield			
35	GM367	Chute Top Shield			
36	GM180	Pivot Spacer			

\* Means Not Shown

# Figure 6 Mill Cylinder

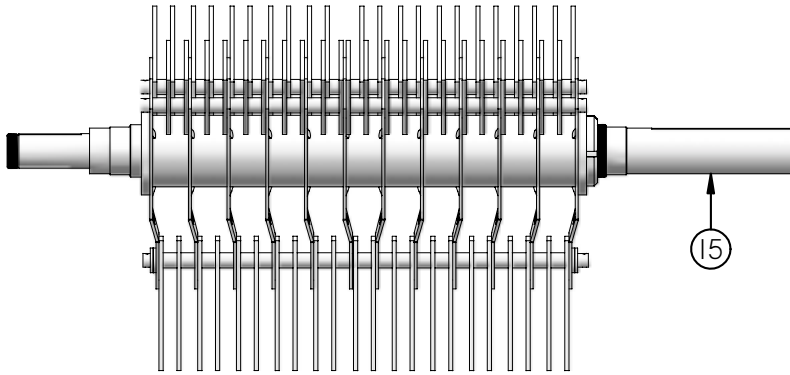

HAMMER REPLACEMENT DETAIL

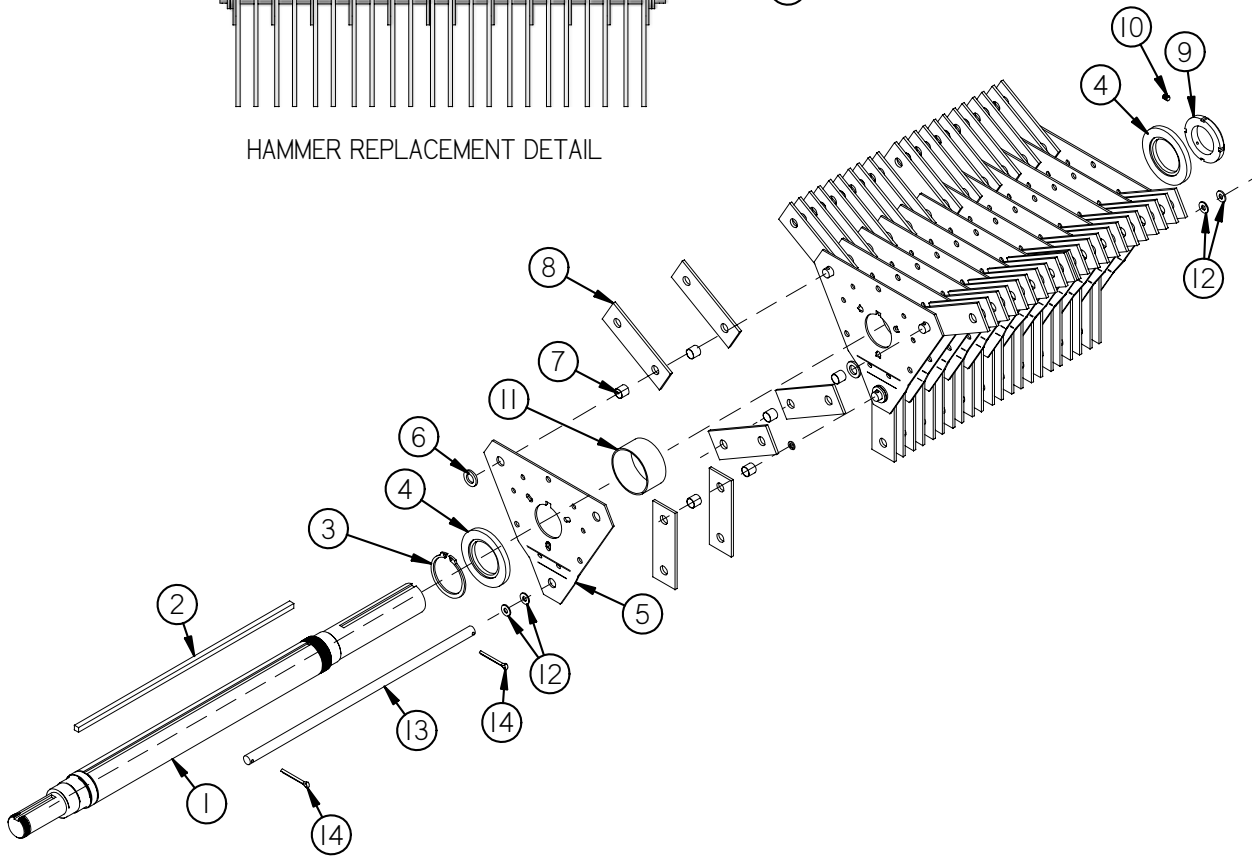

## Figure 6 Mill Cylinder

<b>ITEM #</b>	<b>PART #</b>	<b>DESC.</b>
1	GM168	Mill Shaft
2	GM169	Cylinder Key 3/8" X 19-3/8"
3	GM465	Retaining Ring (EN237)
4	GM171	Retainer Plate
5	GM172	Cylinder Plate (12 Pcs.)
6	GM173	Spacer
7	GM174	Hammer Spacer
8	GM175	Hammer (66 Pcs.)
9	GM176	Cylinder Shaft Nut (N-12)
10	GM277	Set Screw 1/4"-20 X .375
11	GM177	Spacer Plate
12	GM430	Balance Washer (4 Pcs.)
13	GM44	Hammer Shaft
14	HSB53	Cotter Pin (3/16" x 1-1/4")
15	GM451	Complete Mill Cylinder

# Figure 7 Conveyor Drive





## Figure 7 Conveyor Drive

ITEM #	PART #	DESC.	ITEM #	PART #	DESC.
1	GM141	Rod 3/8" X 22.375"	49	F143	Flange (Greaseable)
2	GM247	Sprocket 30T (540 RPM)	*	GM424	1/4"-28 Grease Line Adapter
*	GM248	Sprocket 54T (1000 RPM)	50	F145	Flange
3	GM249	Shear Flange	51	GM361	#60 Chain X 66 Pitches (540RPM)
4	GM479	Bearing Bracket A	*	GM343	#60 Chain X 80 Pitches (1000 RPM)
5	GM491	Bearing (SBRFB 207 20-G)	52	GM393	Auger Seal
6	GM480	Gearbox Shaft Brace	53	S50	Bushing (A-2001 x 1-1/8")
7	GM251	Idler Sprocket (60A15)	54	GM494	Relube Bearing Flange
*	GM246	Bearing (203 RR2 USA Fafnir)	55	GM441	Auger Transition Cap
8	GM252	Idler Spring (077055)	56	GM202	1/2" Plug (5406-8P)
9	GM253	Idler Bracket	57	GM511	Key 5/16" x 1-3/4" Square
10	GM254	Trans. Drive Shaft	58	RG132	Bushing (1.265 ID x 1-1/2" x 2" S-1503)
11	GM255	Intake Conveyor Auger	59	GM36	Grease Line 30"
12	GM469	Sprocket 23T (Double)	60	GM472	Retaining Ring (N5000-102)
13	GM292	Idler Spacer	61	GM474	Tightener Support
14	GM470	Sprocket 26T (Double)	62	GM475	Tightener Support Spacer
15	GM471	#50 Double Chain X 54 Pitch	63	GM507	Grease Line 60"
16	D118	#50 Double Connector Link	64	GM506	Grease Line 51"
17	GM473	Idler Sprocket 8 Tooth	65	F143	Bearing (FH207-22)
*	WM125	Bearing Sprocket (SKF 6000-2RSJEM)	66	F146	Lock Collar
18	GM492	5/16" x 1-1/4" Square Key w/ Round Ends	67	GM510	Mount Plate
19	S435	5/16" X 3/8" Set Screw			
20	D39	Connector Link #60			
21	GM296	Idler Pivot Bushing (3/4" OD x .635" ID x 3/4")			
22	GM481	Gearbox Bearing Plate			
23	45N57	1/4" NPT x 2-5/8" Greasezerk (58754)			
24	GM485	Shaft Shear Hub			
25	WM121	5/16" x 1" Square Key			
26	GM297	Bushing (2.015 ID X 2-1/4 OD X 1.312)			
27	GM298	Transfer Auger Sprocket Washer			
28	GM299	Tensioner Pivot			
29	RGB38	5/16" X 1" GR. 5 Bolt			
30	12V126	5/16" X 2" Bolt			
31	12V66	5/16" X 3/4" Bolt GR 5			
32	D81	5/16" Lock Nut			
33	GM300	5/16" Flat Washer			
34	RGB39	5/16" Lock Washer			
35	T116	5/16" Nut			
36	BFR247	3/8" X 1" Carriage Bolt			
37	B68	3/8" Lock Washer			
38	K60	3/8" Nut			
39	CHM7	3/8" X 3-1/2" Bolt			
40	X67	3/8" Flat Washer			
41	50N183	5/8" X 1-1/4" Bolt			
42	BFR104	3/4" Nylock Nut (Thin)			
43	GM493	1/4" X 1-1/4" GR 5 Bolt			
44	LW140	1/4" Nut			
45	GM273	Gearbox (A11)			
46	WM27	Lock Collar			
47	G89	Grease Zerk			
48	WM29	Bearing (SA207-20G)			

\* Means Not Shown

# Figure 8 Unloading Auger

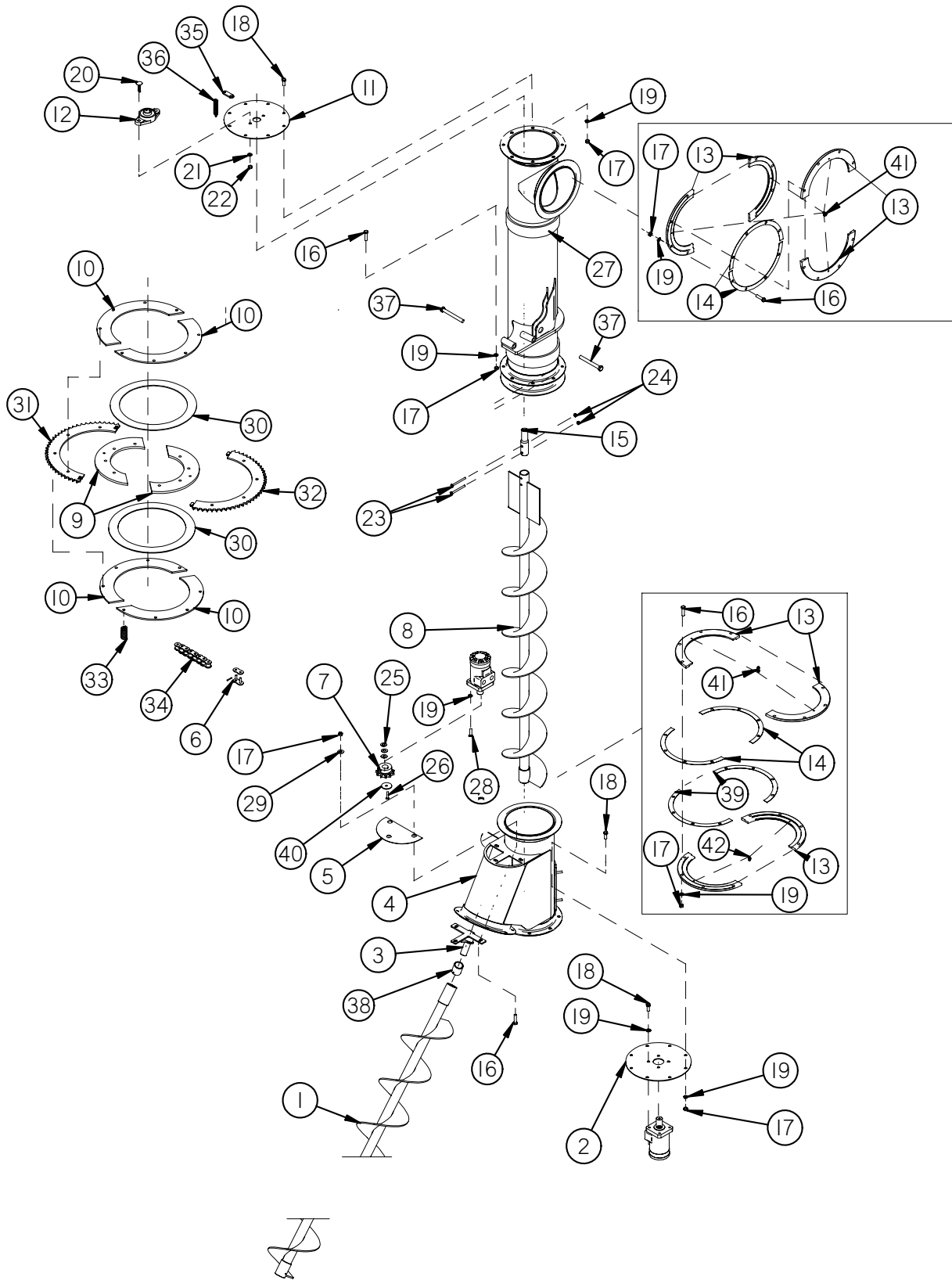

## Figure 8 Unloading Auger

ITEM #	PART #	DESC.
1	GM220	Tank Unloading Auger
2	GM221	Auger Drive Cap
3	GM222	Auger Shaft
4	GM223	Auger Tube
*	GM488**	Auger Cleanout Cover
*	GM509**	Felt Gasket
5	GM224	Overflow Cover
6	D39	#60 Connector Link
7	GM226	Sprocket 60-B11
8	GM227	Vertical Auger
9	GM228	Clutch Plate
10	GM229	Clutch Face
11	GM230	End Cap
12	T40	Bearing
13	GM231	Collar
14	GM232	Collar Shim
15	GM233	Vertical Auger Shaft
16	LW134	3/8" X 1-1/2" GR.5 Bolt
17	K60	3/8" Nut
18	80N57	3/8" X 3/4" Bolt
19	B68	3/8" Lock Washer
20	GM179	5/16" X 1" Carriage Bolt
21	RGB39	5/16" Lock Washer
22	T116	5/16" Nut
23	GM235	1/4" X 2-1/4" Bolt
24	D65	1/4" Lock Nut
25	T16	1/4" Flat Washer
26	23N223	1/4" X 1-1/4" Bolt
27	GM236	Pivot Tube
28	X111	3/8" X 1" Bolt
29	X67	3/8" Flat Washer
30	GM237	Clutch
31	GM238	Turn Sprocket B
32	GM239	Turn Sprocket A
33	WM210	Clutch Spring (Red)
34	GM409	#60 Chain x 81 Pitches
35	GM436	Hose Holder
36	23N187	Spring
37	9S16	1/2" x 4-1/2" Bolt (Full Thread)
38	RG11	Bushing (1.010" ID x 1-1/4" x 2")
39	GM459	Collar Shim
40	GM461	Pinion Stop
41	RG51	1/4"-28 90° Grease Zerk (1911)
42	G89	1/4"-28 Grease Zerk (1641)

\* Means Not Shown

\*\* Means Used on Serial #900104 and Higher

# Figure 9 12' Unloading Auger

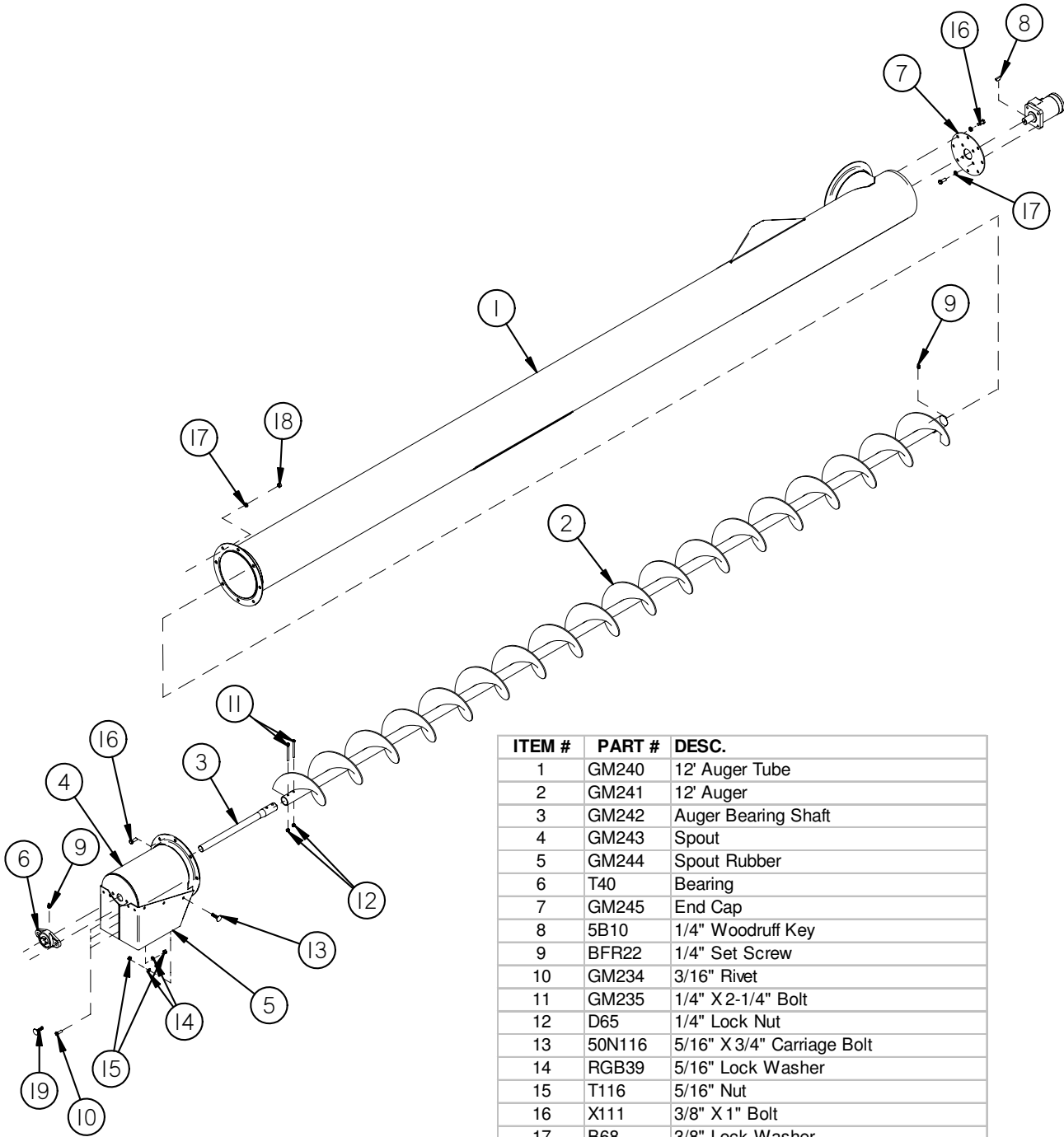

ITEM #	PART #	DESC.
1	GM240	12' Auger Tube
2	GM241	12' Auger
3	GM242	Auger Bearing Shaft
4	GM243	Spout
5	GM244	Spout Rubber
6	T40	Bearing
7	GM245	End Cap
8	5B10	1/4" Woodruff Key
9	BFR22	1/4" Set Screw
10	GM234	3/16" Rivet
11	GM235	1/4" X 2-1/4" Bolt
12	D65	1/4" Lock Nut
13	50N116	5/16" X 3/4" Carriage Bolt
14	RGB39	5/16" Lock Washer
15	T116	5/16" Nut
16	X111	3/8" X 1" Bolt
17	B68	3/8" Lock Washer
18	K60	3/8" Nut
19	GM179	5/16" X 1" Carriage Bolt

# Figure 10 Shields

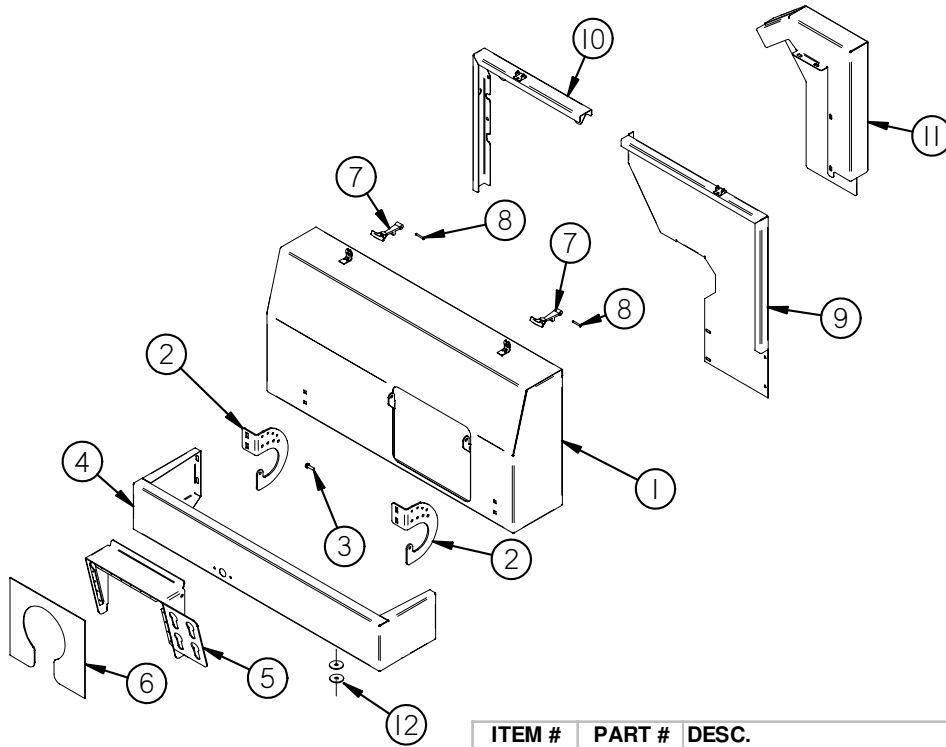

ITEM #	PART #	DESC.
1	GM321	Front Shield
2	GM322	Shield Hinge
3	RGB38	5/16" x 1" GR. 5 Bolt
*	D110	1/4" x 1" GR.5 Bolt
4	GM324	Flywheel Shield Lower
5	GM325	PTO Guard
6	GM326	Poly PTO Guard
7	X192	Rubber Latch
8	X195	Latch Pin
9	GM327	Flywheel Shield Back Left
10	GM328	Top Seal
11	GM329	Hydraulic Pump Shield
12	S304	Washer

\* Means Not Shown

**Figure 11**  
**Oiler**

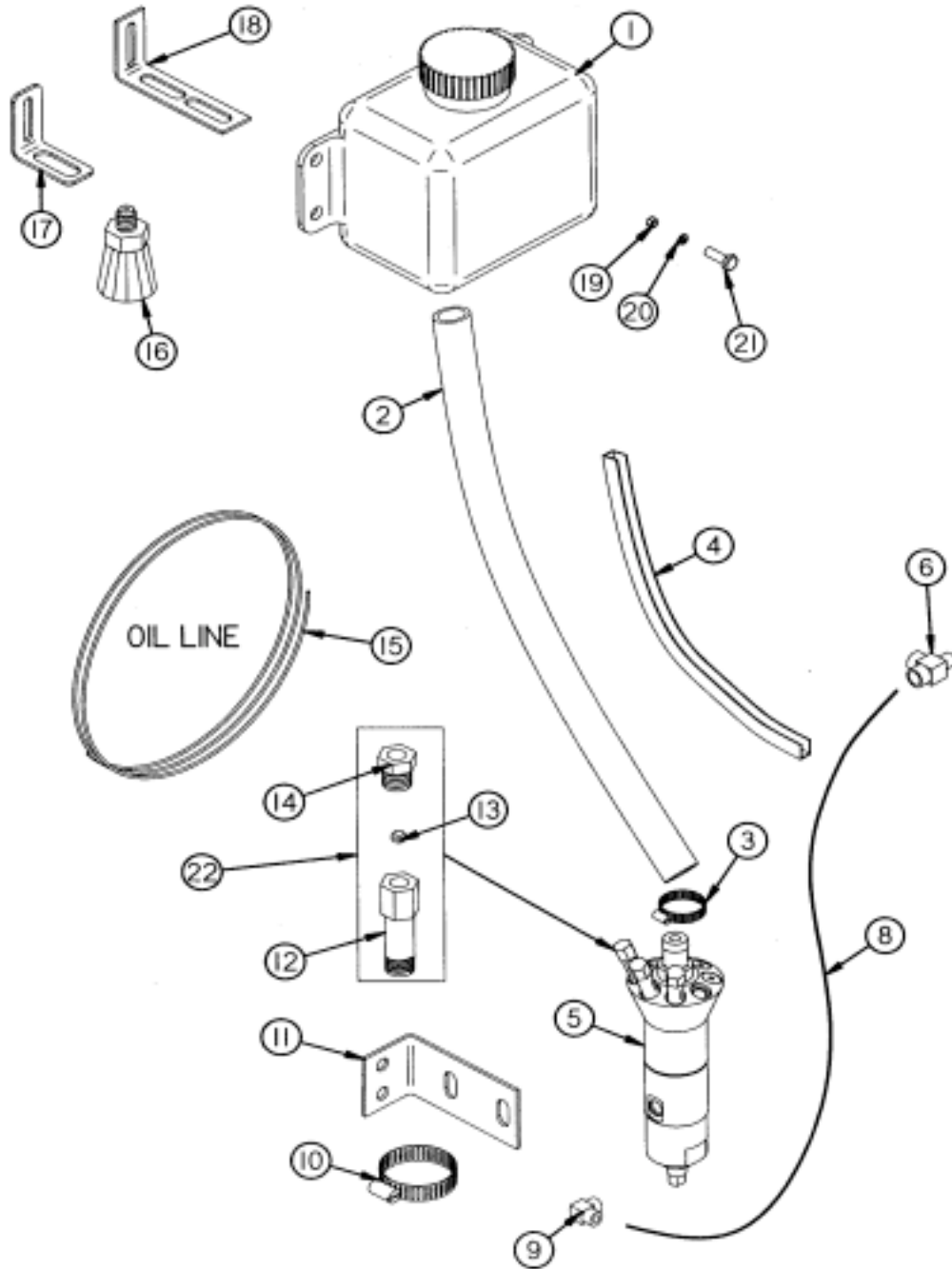



# Figure 11 Oiler

ITEM #	PART #	DESC.
1	HGV63	Reservoir
2	HGV66	Filler Hose
3	HGV75	1" Hose Clamp
4	HGV77	Edging 12"
5	HGV82	Pump (Complete)
6	23N116	3/8" Street Tee (Chamfer on Male End)
8	GM501	Hydraulic Hose (1/4" x 29-3/4")
9	HGV65	O-Ring /Jic Elbow
10	HGV74	2" Hose Clamp
11	HGV68	Pump Mount Bracket
12	HGV86	Standoff
13	HGV87	Ferrule
14	HGV85	Sleeve Nut
15	GM504	Oiler Tube (2 pcs. 5/16" OD x 48") Back
*	GM505	Oiler Tube (1 pc. 5/16" OD x 156") Front
16	HGV67	Brush
17	GM490	Brush Bracket Short (Front)
18	HGV69	Brush Bracket Long (Back)
19	LW140	Nut (1/4"-20)
20	K84	1/4" Lock Washer
21	D110	Bolt (1/4" x 1")
22	HGV84	Manifold Assembly (Complete)
*		Oiler Kit (Complete)

\* Means Not Shown

# Figure 12 Auger Circuit

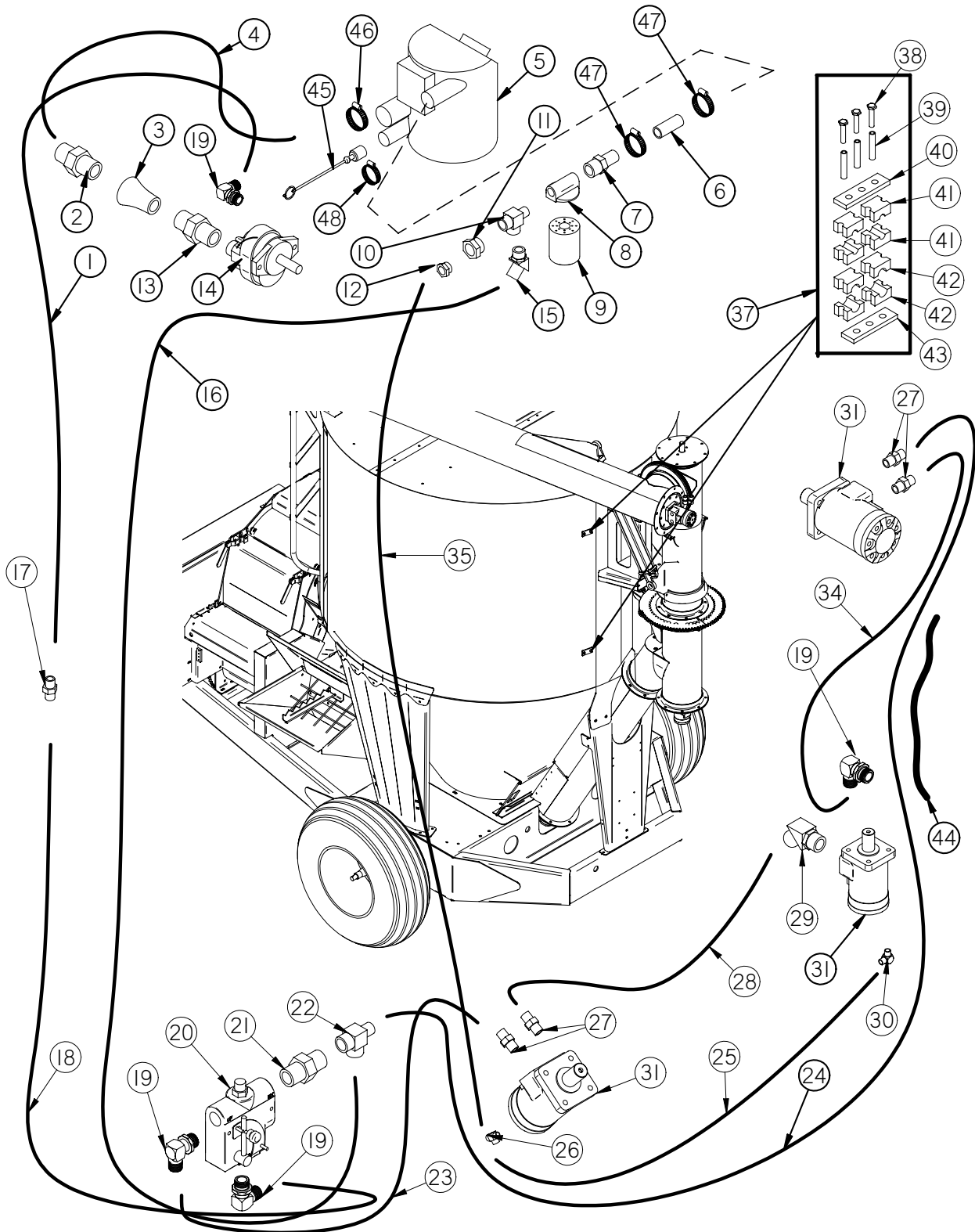

## Figure 12 Auger Circuit

ITEM #	PART #	DESC.
1	GM1	1/2" X 32" Hose
2	GM2	Adapter (24FTX-S)
3	GM3	Pipe Reducer (1-1/2" NPT TO 3/4")
4	GM4	1-1/2" X 64" Suction Hose
5	GM5	Reservoir
6	GM6	3/4" X 3" Hose
7	GM7	3/4" Hose Barb
8	LW288	Filter Head
9	LW289	Filter Element
10	GM10	3/4" Street Tee (3/4 MRO)
11	GM11	Reducer (3/4 X 1/4 PTR)
12	GM12	Adapter (4-4 FTX)
13	GM13	Adapter (12-3/4 F50F-S)
14	GM14	Pump
15	GM15	45° Elbow (12VTX)
16	GM16	3/4" X 76" Hose
17	GM17	Union (8 HTX)
18	GM18	1/2" X 75" Hose
19	GM19	Elbow (8-10 C50X)
20	GM20	Flow Control
21	GM21	Adapter (12-10 F50X-S)
22	GM22	Tee (12R6X)
23	GM23	1/2" X 30" Hose
24	GM24	1/2" X 160" Hose
25	GM25	1/4" X 80" Hose
26	GM26	Tee (4R50X-S)
27	GM27	Adapter (8-10 F50X)
28	GM28	1/2" X 79" Hose
29	GM29	45° Elbow (8-10 V50X)
30	GM30	Elbow (4C50X-S)
31	GM464	Motor (101-2180-009)
34	GM34	1/2" X 116" Hose
35	GM35	1/4" X 51" Hose
37	GM8	Hose Clamp 3/8" X 1/2" (Complete)
38	GM62	Bolt
39	GM63	Tube
40	GM64	Top Plate
41	GM65	3/8" Insert
42	GM66	1/2" Insert
43	GM67	Weld Plate
44	GM32	Spiral Wrap (HG125) 1-1/4" x 2'
45	GM37	Port Cap (TFH-38)
46	GM38	1-1/2" Hose Clamp
47	DWM123	1" Hose Clamp
48	GM453	1" Hose Clamp

# Figure 13 Auger Swing Circuit

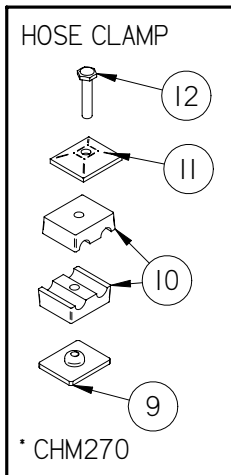
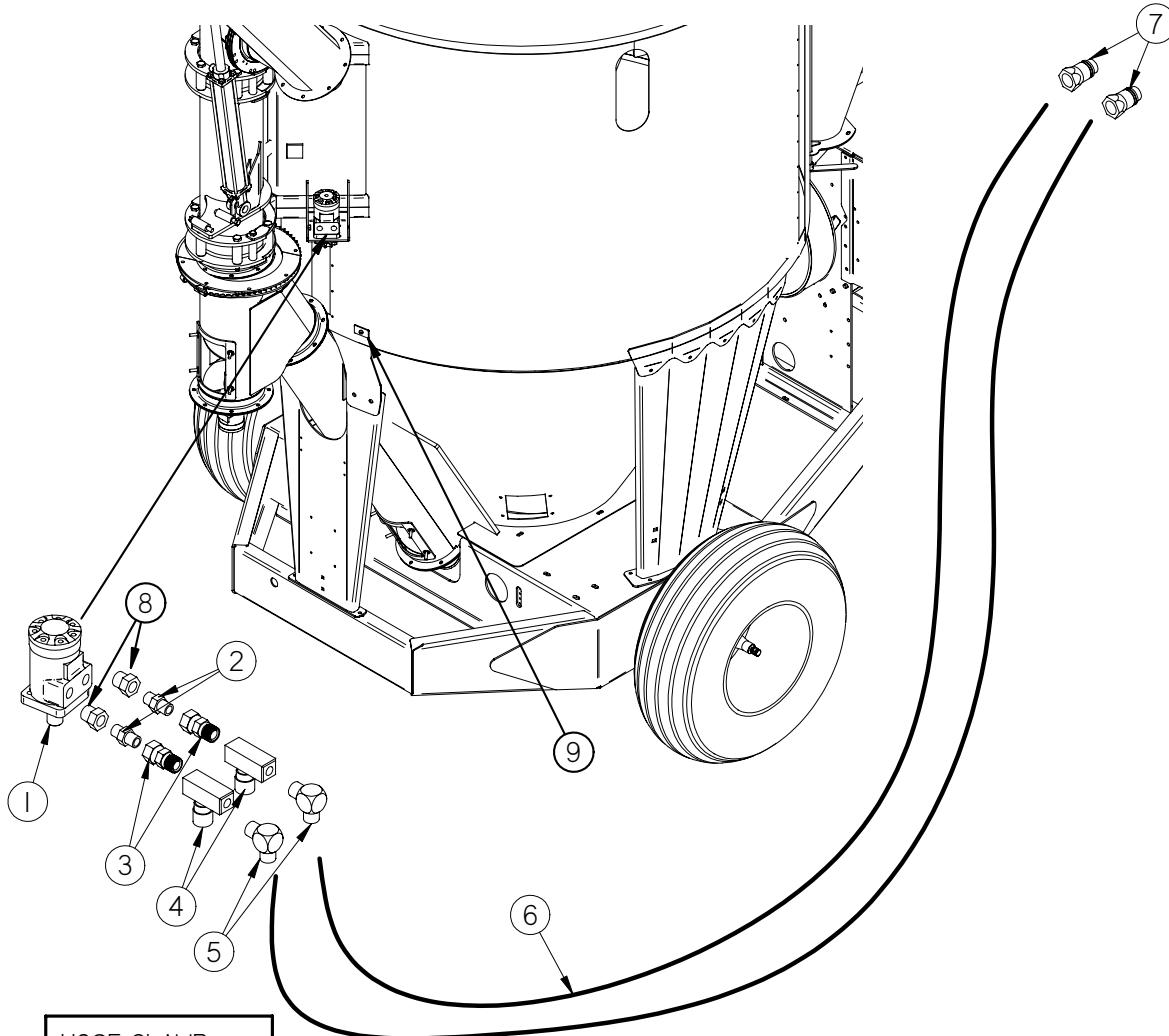

ITEM #	PART #	DESC.
1	GM412	Motor (Parker) TB0390FP100AAB
2	16SV351	3/8" Nipple Nut (5404-6-6)
3	DWM233	3/8" Male Union Adapter
4	CHM265	Needle Valve (F600S)
5	GM42	Elbow (6-6 CTX)
6	GM43	3/8" X 264" Hose
7	DWM205	1/2" Male Coupler
8	JB82	Bushing 1/2" to 3/8" (5406-8-6)
9	CHM279	Weld Plate
10	CHM278	Clamp Halves 3/8" Hose
11	CHM277	Cover Plate
12	CHM276	Hex Bolt
*	CHM270	Complete 3/8" Hose Clamp (Double)

\* Means Not Shown

# Figure 14 Auger Lift Circuit

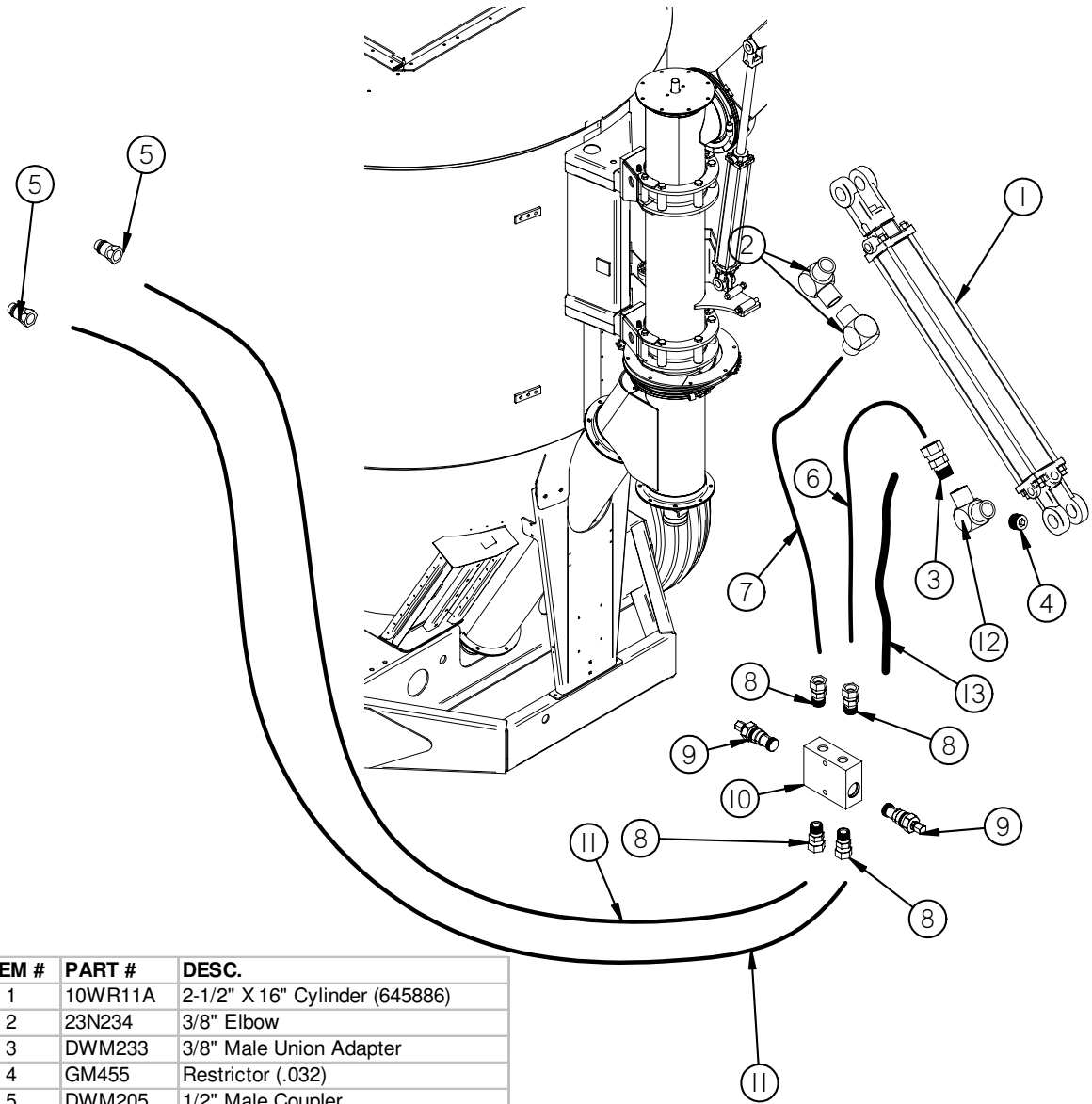

ITEM #	PART #	DESC.
1	10WR11A	2-1/2" X 16" Cylinder (645886)
2	23N234	3/8" Elbow
3	DWM233	3/8" Male Union Adapter
4	GM455	Restrictor (.032)
5	DWM205	1/2" Male Coupler
6	GM45	3/8" X 130" Hose
7	GM46	3/8" X 125" Hose
8	GM47	Adapter (0507-6-6)
9	GM48	Relief Cartridge
10	GM49	Relief Valve Body
*	GM50	Relief Valve Complete
11	GM51	3/8" X 240" Hose
12	GM446	3/8" Street Elbow w/ Restrictor
13	GM32	Spiral Wrap (HG125) 1-1/4" x 2'

\* Means Not Shown

# Figure 15 Gearbox (All)

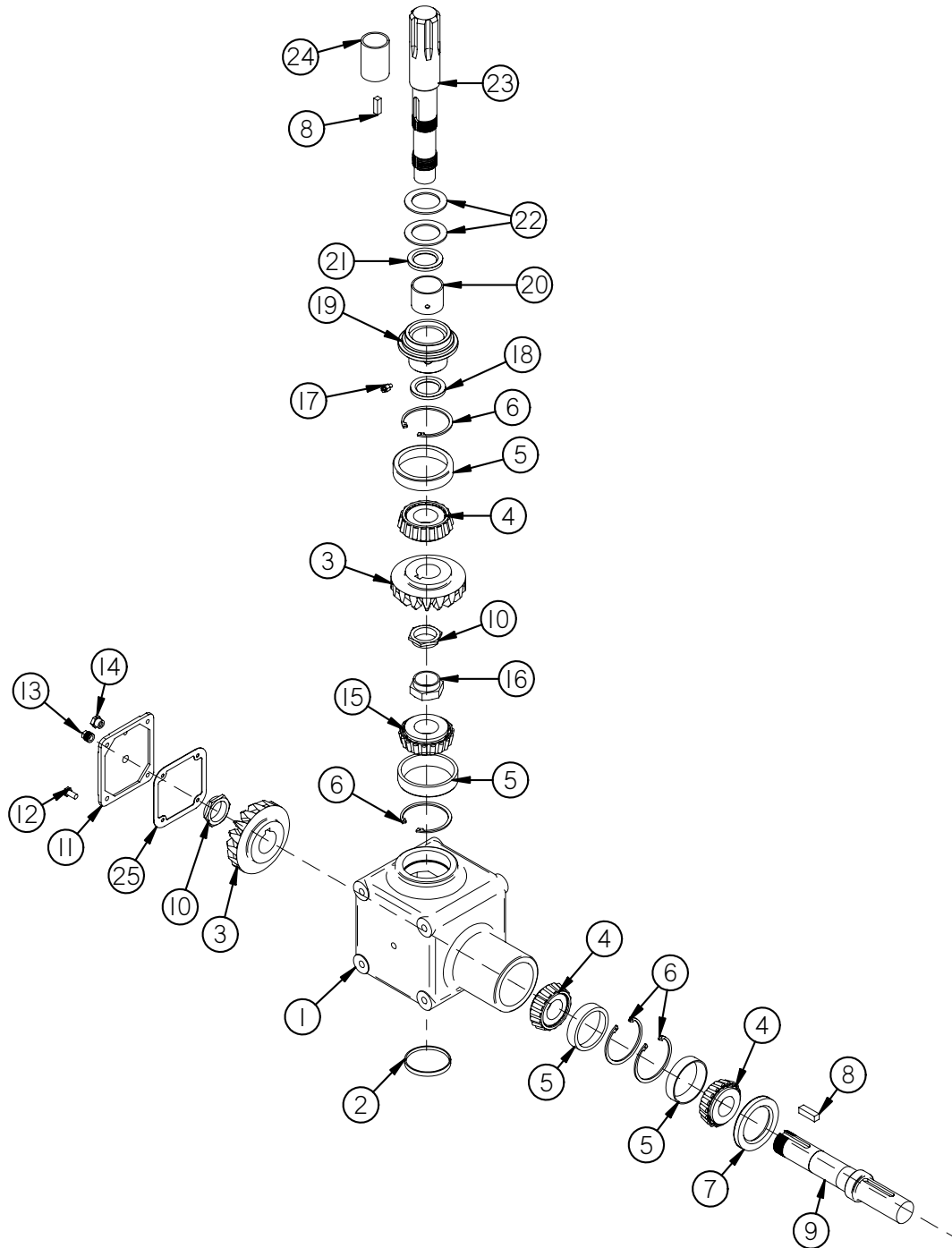



## Figure 15 Gearbox (All)

ITEM #	PART #	DESC.
1	G50	Housing
2	G68	Cap
3	G52	Bevel Gear
4	G53	Bearing Cone (14139A)
5	G54	Bearing Race (14276)
6	G55	Snap Ring
7	G64	Seal (F465)
8	G62	Key 3/8" x 1-3/8" (Hardened)
9	GM495	Input Shaft
10	G58	Stake Nut (1-3/8"-18)
11	GM484	Cover
12	G56	Capscrew
13	G65	Plug 3/8" NPT
14	G67	Vent 1/8" NPT
15	GM496	Bearing Cone (14117A)
16	GM486	Stake Nut Long (1-3/8"-18)
17	GM497	Fitting (O-Ring 1/8"-27 NPT)
18	GM498	Seal (19739)
19	GM482	Gearbox Seal Extension
20	GM487	Bushing (2-1/4" OD x 2" ID x 1.765)
21	GM499	Seal (19786)
22	RG24	Thrust Washer (2" ID x 3" OD x 1/8")
23	GM500	Output Shaft
24	GM483	Gearbox Output Bushing
25	G66	Gasket
*	GM273	Complete Machine Gearbox

\* Means Not Shown

# Figure 16

## PTO

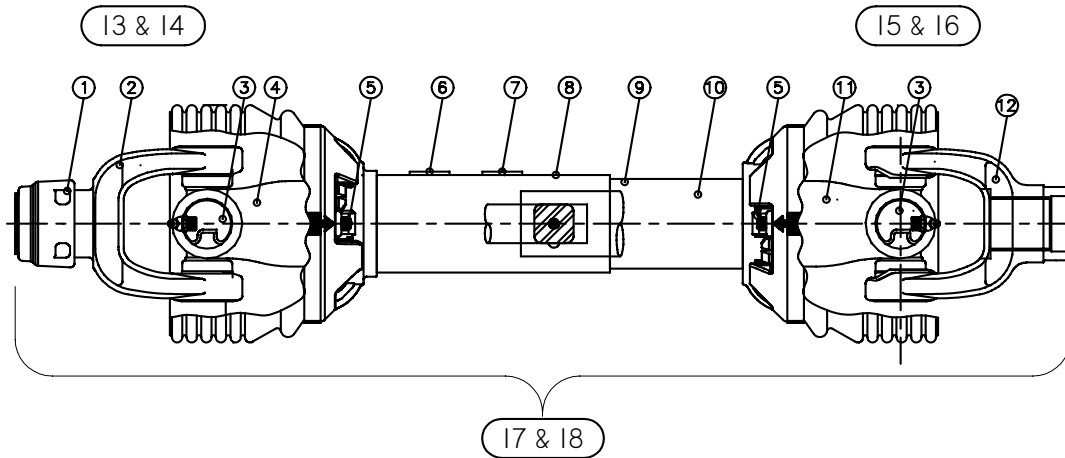

ITEM #	540 RPM	1000 RPM 1-3/8"	DESC.
1	16SV274	"	Safety Slide Lock Repair Kit
2	GM374	GM375	Safety Slide Lock Yoke Assembly
3	GM376	"	55R Cross & Bearing Kit
4	GM377	"	Yoke & Shaft
5	GM378	"	Nylon Repair Kit (Not Shown)
6	16SV283	"	Safety Sign
7	GM379	GM380	Safety Sign
8	GM381	GM476	Outer Guard
9	GM382	"	Inner Guard
10	16SV286	"	Safety Sign (Not Shown)
11	GM383	"	Yoke, Tube & Slip Sleeve
12	GM384	"	Yoke
13	GM385	GM477	Joint & Shaft Half Assembly w/Guard
14	GM386	GM478	Joint & Shaft Half Assembly
15	GM387	"	Joint & Tube Half Assembly w/Guard
16	GM388	"	Joint & Tube Half Assembly
17	GM389	-	Complete PTO 540 RPM (262-23944)
18	-	GM390	Complete PTO 1000 RPM 1-3/8" (262-23956)

# Figure 17 Infeed Conveyor Pivot

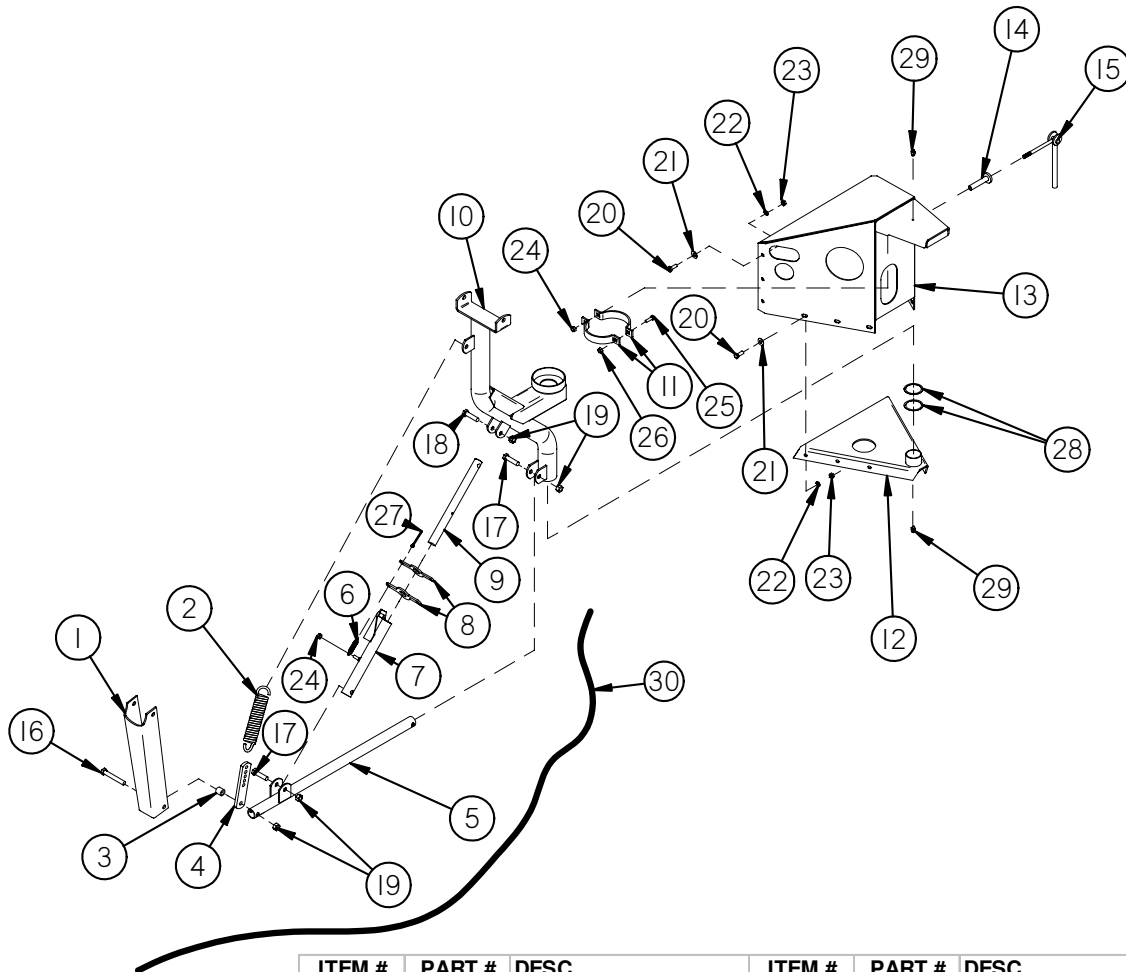

ITEM #	PART #	DESC.	ITEM #	PART #	DESC.
1	GM203	Support	16	LW131	1/2" X 3-1/2" Bolt
2	GM204	Spring (40174)	17	BFR119	1/2" X 2-1/4" Bolt
3	GM205	Spacer	18	F52	1/2" X 2" Bolt
4	GM206	Spring Adjustment	19	R11	1/2" Lock Nut
5	GM207	Pivot Linkage	20	X111	3/8" X 1" Bolt
6	GM208	Spring (17H387)	21	X67	3/8" Flat Washer
7	GM209	Locking Tube	22	B68	3/8" Lock Washer
8	GM210	Locking Lever	23	K60	3/8" Nut
9	GM211	Locking Shaft	24	K93	3/8" Lock Nut
10	GM212	Pivot Main Support	25	GM218	5/16" X 1-1/4" Bolt
11	GM213	Brake Band	26	D81	5/16" Lock Nut
12	GM214	Bottom Support	27	HSB55	3/16" X 1" Cotter Pin
13	GM215	Top Support	28	GM219	Pivot Spacer
14	GM216	Lever Guide	29	RG51	Grease Fitting 90°
15	GM217	Brake Lever	30	GM434	Trip Rope

# Figure 18 Infeed Conveyor

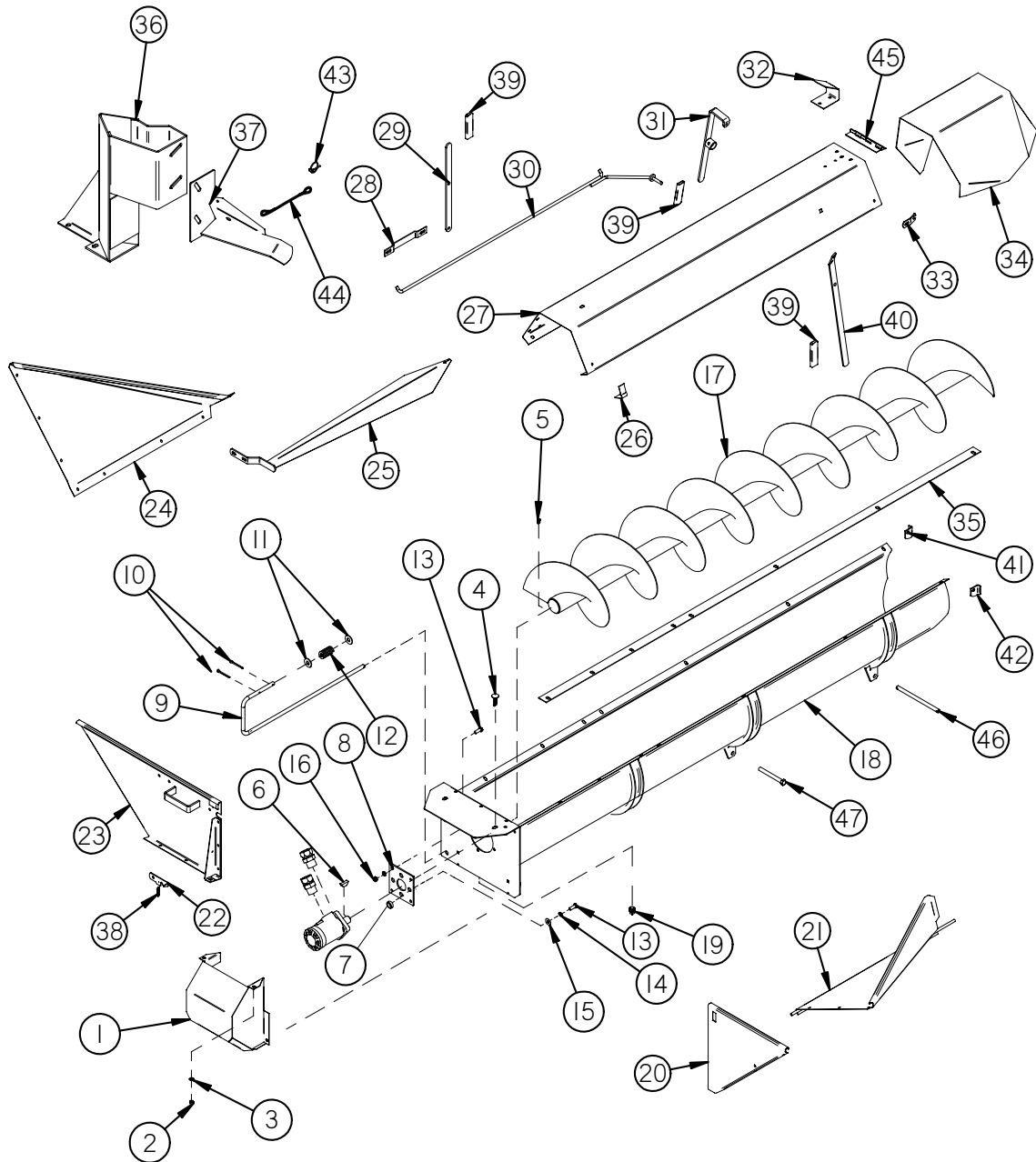

## Figure 18 Infeed Conveyor

ITEM #	PART #	DESC.
1	GM178	Shield
2	T116	5/16" Nut
3	RGB39	5/16" Lock Washer
4	GM179	5/16" X 1" Carriage Bolt
5	BFR22	1/4"-20 x 1/2" Set Screw
6	5B10	1/4" Key
7	GM180	Spacer
8	GM181	Motor Mount
9	GM182	Handle Latch
10	X43	1/8" X 1" Cotter Pin
11	K68	1/2" Flat Washer
12	17G128	Spring
13	G110	3/8" X 3/4" Bolt
14	B68	3/8" Lock Washer
15	X67	3/8" Flat Washer
16	K60	3/8" Nut
17	GM184	Auger
18	GM185	Trough
19	GM202	1/2" Plug (5406-8P)
20	GM186	Trough End Right
21	GM187	Side Trough
22	GM188	Trough Latch
23	GM189	Trough End
24	GM190	Trough Side Left
25	GM191	Auger Guard
26	GM192	Support Pivot
27	GM193	Conveyor Cover
28	GM194	Handle Guide
29	GM195	Handle
30	GM196	Flow Control Rod
31	GM197	Flow Control Handle
32	GM198	Trough Extension Stop
33	GM199	Cover Holder
34	GM200	Trough Extension
35	GM201	Scraper
36	GM54	Transport Post
37	GM75	Transport Support
38	GM208	Latch Spring (17H387)
39	GM370	Handle Grip
40	GM371	Control Handle
41	GM372	Cover Stop Right
42	GM373	Cover Stop Left
43	PB190	Lynch Pin
44	S122	Lanyard
45	GM126	Hinge
46	GM458	Pivot Pin
47	BFR224	1/2" x 4-1/2" GR5 Bolt

# Figure 19 Infeed Auger Circuit

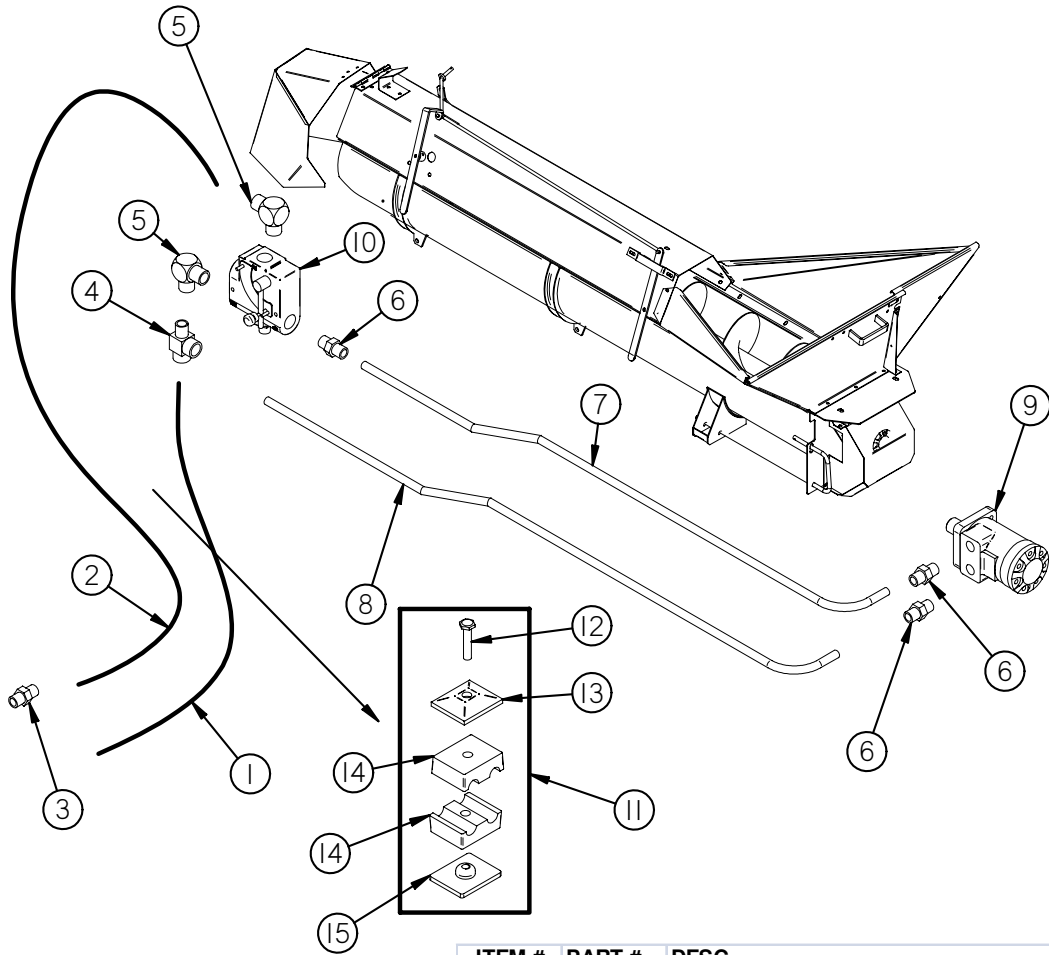

ITEM #	PART #	DESC.
1	GM52	1/2" X 81-1/4" Hose
2	GM53	1/2" X 97-1/2" Hose
3	GM17	Adapter (8 HTX)
4	GM55	Tee (10 R6X)
5	GM56	Elbow (10 C50X)
6	GM57	Adapter (10 F50X)
7	GM58	Pressure Tube
8	GM59	Return Tube
9	GM61	Motor (101-1013-009)
10	GM20	Flow Control
11	GM9	Hose Clamp 1/2" Twin (Complete)
12	GM68	Bolt
13	GM69	Top Plate
14	GM70	1/2" Insert
15	GM71	Weld Plate



# Figure 20

## 3' & 6' Auger Extension

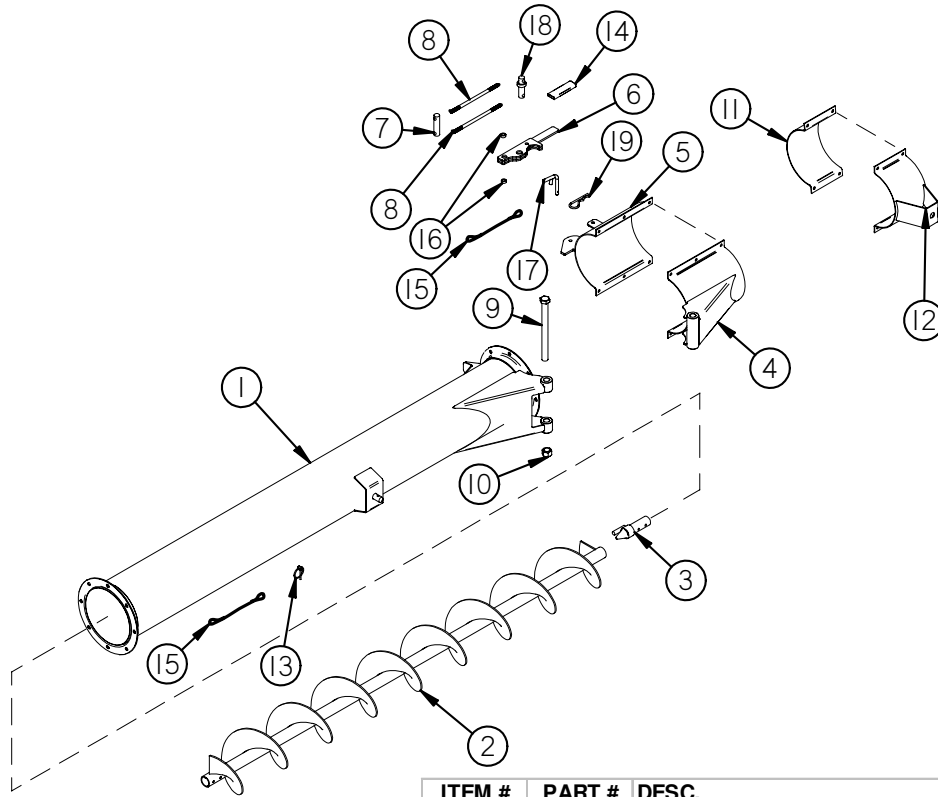

ITEM #	PART #	DESC.
1	GM278	6' Extension
*	GM279	3' Extension
2	GM280	6' Auger
*	GM281	3' Auger
3	GM282	Auger Connect Shaft
4	GM283	Pivot Clamp
5	GM284	Latch Clamp
6	GM285	Latch Handle
7	GM286	Latch Pivot Shaft
8	GM287	Latch Rod
9	GM288	Bolt 3/4" x 9" GR.5
10	HE7	3/4"-10 Lock Nut
11	GM289	Transport Lock Clamp
12	GM290	Transport Lock Latch
13	PB190	Lynch Pin
14	GM370	Handle Grip
15	S122	Lanyard
16	GM180	Pivot Spacer
17	GM39	Latch Pin
18	GM369	Latch Pivot Pin
19	ES7	Hair Pin

\* Means Not Shown

# Figure 21 Optional Lights & Fenders

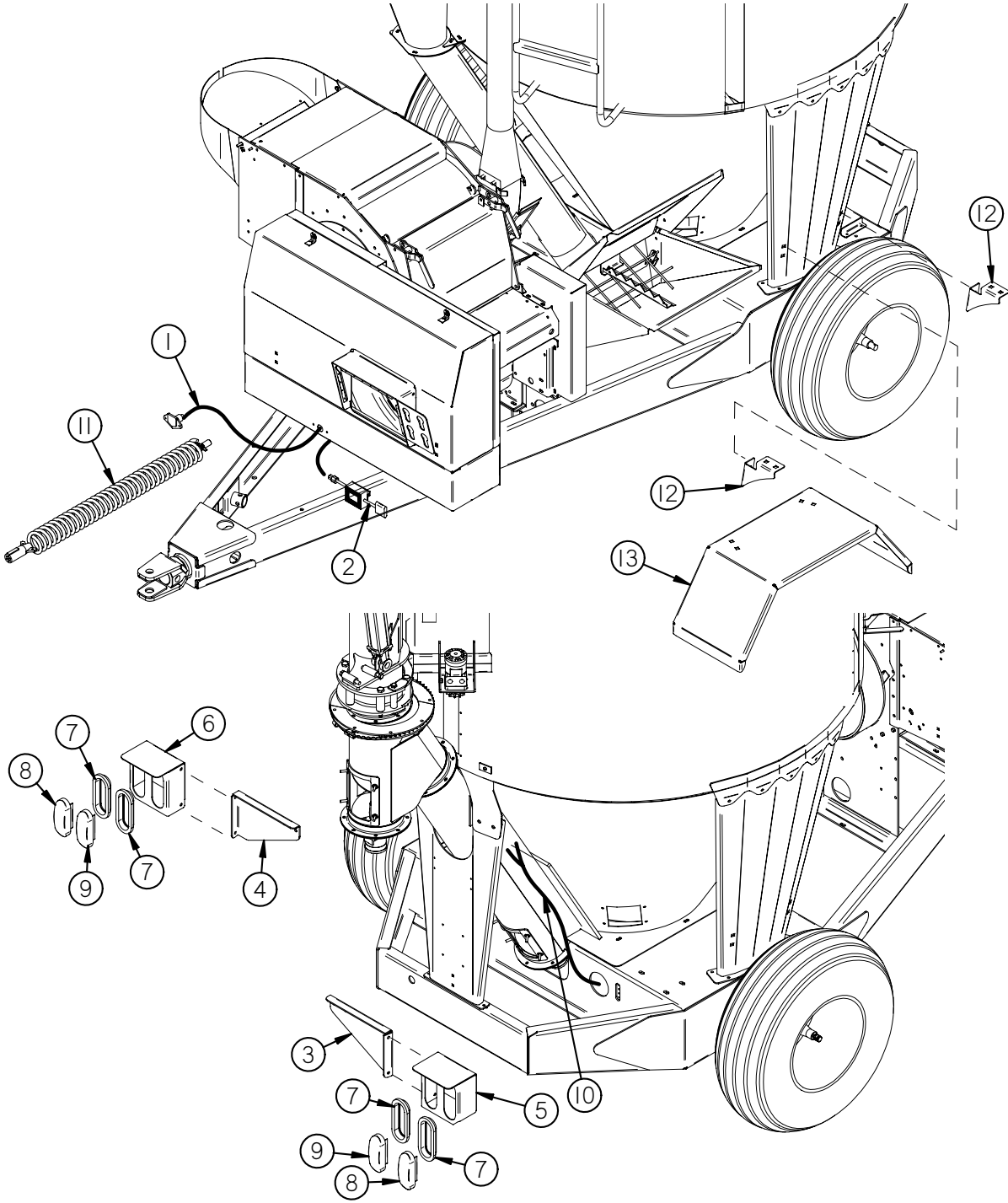

# Figure 21

## Optional Lights & Fenders

### LIGHTS

ITEM #	PART #	DESC.
1	56N154	Flasher Module Loom
2	S441	Flasher Module
3	GM330	Light Bracket Right
4	GM331	Light Bracket Left
5	55N62	Light Housing Right
6	55N61	Light Housing Left
7	S308	Rubber Grommet
8	S309	Amber Hazard Light
9	S310	Red Hazard Light
10	GM502	Light Harness
11	S317	Optional Tractor Cord

### FENDERS

12	GM332	Fenders Support
13	GM333	Fender (Fits Either Side)

## Figure 22 Optional Scale

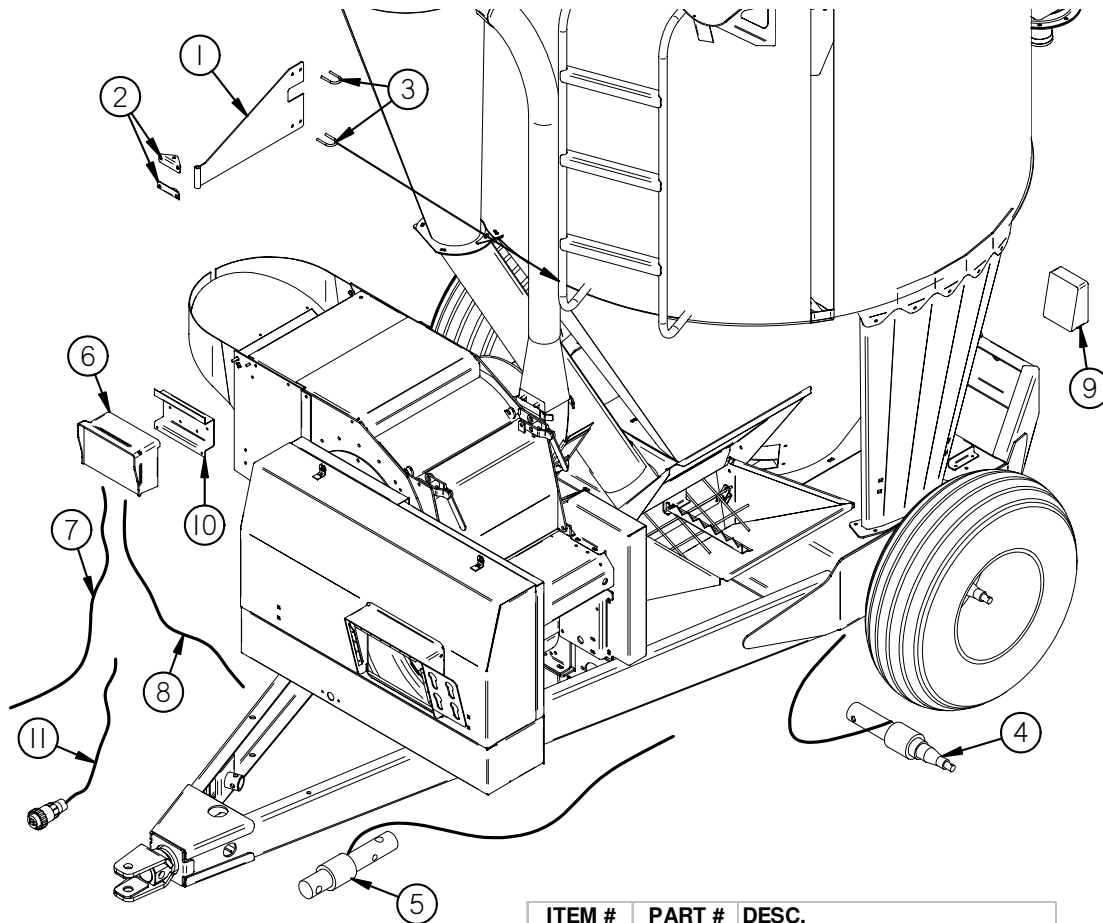

ITEM #	PART #	DESC.
1	GM400	Control Box Arm
2	GM401	Control Box Mount
3	GM119	U Bolt 5/16" x 2"
4	GM402	Spindle Load Cell (146772)
5	GM403	Hitch Load Cell (143480)
6	GM404	Scale Display (400590)
7	GM405	Power Cord
8	GM406	Junction Box Cord
9	GM407	Junction Box (404465)
10	GM408	Scale Hanger Bracket (840459)
11	16SV269	Tractor Power Cord

# H&S GM 170 Specifications

Tank Capacity –Bushel	135
Tank Capacity – Cubic Ft.	170
Tank Diameter	72”
Diameter of Mixing Auger	14” Diameter w/30” Base
Ladder	Standard -Front Mount Over Mill
Tank Windows	2 Full Length & 1 Port Hole Style
Overall Height	10’ 7”
Overall Width	7’ 9” w/o Auger Feeder
Overall Width	8’ 8” w/Auger Feeder
Overall Length	15’ 8”
Ground Clearance	11½”
Supplement Hopper	23”W x 18”L - 35” Above Ground
Feeder	Gravity Hopper or Feed Auger
PTO Drive	540 or 1000 RPM
H.P. Requirement	540 RPM up to 115 HP - 1000 RPM up to 145 HP
Tires	12.5L-15 - 20 Ply
Jack	Standard
Weight w/Auger Feeder	3,600#

## **Auger Feeder**

Auger Feeder Length	84”
Auger Feeder Auger Diameter	12”
Infeed Hopper	42” w/Fold-In-Flare - Adjustable as low as 20”
Drive	Direct Drive Independent Hydraulic Motor

## **Mill**

Hammermill Width	21”
Cylinder Diameter	20”
Grinder Drive	8 - “A” Section Banded V-Belt
Grinder Hammers	66–4 Way Reversible Steel Alloy
Grinder Screen Area	600 Square Inches
Throat Magnets	2 - 4” x 18”
Speed	2700 RPM

## **Discharge Conveyor**

Unloading Auger Tube Diameter	8”
Unloading Auger Length	12’
Unloading Auger Rotation	300 Degrees
Unloading Auger Reach Standard	19’ @ 53 Degrees

## **Drive System - Self-Contained - Includes Pulley-Driven Pump, Reservoir & Pressure Relief Valve**

Pump Pressure	3,200 PSI Maximum
Oil Flow	10.5 G.P.M.
Hydraulic Reservoir	Cyclonic Reservoir
Oil Filter	10 Micron

**SPECIFICATIONS ARE SUBJECT TO CHANGE WITHOUT NOTICE**

**H&S MFG. CO.**

products approved

for the

**FEMA**

**SEAL OF QUALITY**

